

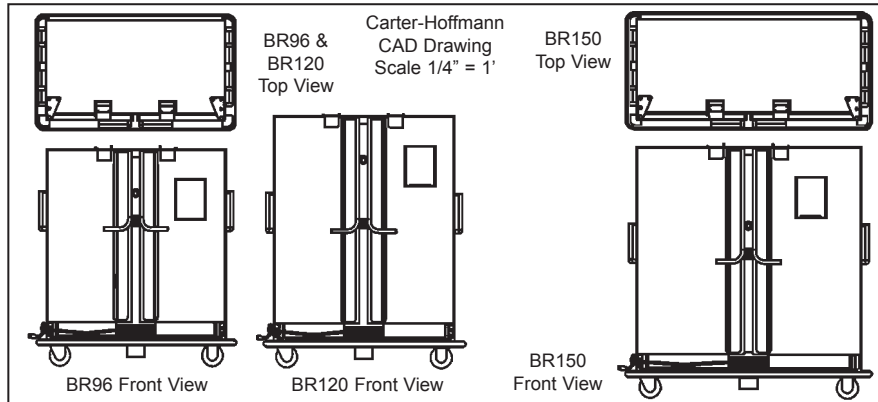

BR SERIES ENDURAHEAT™ BANQUET CARTERS

Heat Retention Carts For Preplated Banquet Meals

CARTER-HOFFMANN
11
FOOD SERVICE EQUIPMENT
BANQUET CARTS



Model Number	Plate Capacity* (covered only) 8 ³ / ₄ " - 11" dia.	Number of Shelves	Clearance Between Shelves		Shelf Size		Overall Dimensions			Caster Diameter		Shipping Weight				
			in	mm	in	mm	Height	Depth	Width	in	mm	lbs	kgs			
<input type="checkbox"/> BR96	96	3	13 ¹ / ₄	337	22 ¹ / ₈ x47	546x1194	60	1524	32 ¹ / ₂	826	57 ⁵ / ₈	1464	6	152	504	229
<input type="checkbox"/> BR120	120	3	16 ¹ / ₂	419	22 ¹ / ₈ x47	546x1194	69 ³ / ₄	1772	32 ¹ / ₂	826	57 ⁵ / ₈	1464	6	152	557	253
<input type="checkbox"/> BR150	150	3	16 ¹ / ₂	419	22 ¹ / ₈ x58 ¹ / ₂	546x1486	69 ³ / ₄	1772	32 ¹ / ₂	826	69 ³ / ₈	1762	6	152	582	264

*Capacity depends on stacking height of plates and covers (see "Clearance Between Shelves"). Maximum diameter includes cover.

CONSTRUCTION... Completely welded double wall cabinet construction with outer cabinet formed and welded to base. All seams turned in to eliminate raw edges.

CABINET MATERIAL... Nickel-bearing type 300 series stainless steel; 20 gauge polished exterior and 24 gauge interior.

BASE FRAME... 12 gauge stainless steel full depth caster bolsters with 16 gauge stainless steel square tubing welded to bolsters.

CASTERS... 6" diameter, industrial grade balloon casters. Sealed roller axle bearing and double ball bearing swivel. Zerk grease fittings. Plate mounted and bolted to base in offset "wheel ahead" pattern. Two casters fitted with brakes.

BUMPER... Non-marking gray vinyl bumper set in heavy-duty 3/16" thick extruded aluminum frame with reinforced corner cutouts. Reinforced with 12 gauge angle brackets welded to cart and bolted through bumper.

INSULATION... 2" thick high density continuous wrap-around type fiberglass insulation.

GASKET... High temperature silicone gasket mounted to cabinet.

DOORS... Welded double panel pocket style stainless steel door. 20 gauge polished exterior and 20 gauge interior. Filled with 1 1/2" thick high-density fiberglass insulation. 8 1/2"x11" menu card holder mounted to right door (not shown).

HINGES... 16 gauge stainless steel full length 1" tubular hinge, mounted with 12 gauge stainless steel brackets and 16 gauge backup plates, with five 5/16-18 bolts and brass bushings.

ERGONOMIC PUSH HANDLES... Two 1" 18 gauge diameter stainless steel tubular handles bolted to cabinet with 12 gauge backup plates.

ERGONOMIC DOOR HANDLE & ROLLER LATCH... Two 1" diameter stainless steel door handles mounted with backup plates. Roller latches with stainless steel strike plates.

TRANSPORT LATCHES... 12 gauge stainless steel top mounted transport latches with padlock provision (not shown).

SHELVES... Welded, duplex nickel-plated removable wire shelves.

THERMOMETER... Dial type with remote sensing bulb and sensing bulb protector. Mounted to center mullion.

HEATING SYSTEM... Bottom mounted heater. Stainless steel construction with black anodized exterior. Removable without tools. 1900 watt inconel-sheathed heating element. High impedance protected, internally cooled fan motor. Patented solid to solid phase change heat retention material. Toggle switch for convection mode or EnduraHeat mode. Full range thermostat and power indicating lights for convection heat mode and EnduraHeat mode. Enduraheat charge ready light.

ELECTRICAL CHARACTERISTICS... Operates on 120 volts, 60 cycle, single phase, 1950 watts, 15.3 amps. Ten foot power cord with reinforced cord grip and 3 prong grounding plug. NEMA 5-20P.

PERFORMANCE... Capable of heating to 200° F (94° C). Convection mode preheat to 160° F (71° C) in approximately 20 minutes. EnduraHeat mode charge/preheat time to 180° F (82° C) in approximately one hour.

- ACCESSORIES/OPTIONS...**
- 4 Wheel Brakes
 - Alternate Wheel Sizes and Tread Types
 - Alternate Electrical Configurations
 - Off position on heater toggle switch

Specifications subject to change through product improvement & innovation.

Patent Pending

CARTER-HOFFMANN

A Division of Carrier Commercial Refrigeration, Inc.
1551 McCormick Ave., Mundelein, IL 60060

(847) 362-5500 • (800) 323-9793 • Fax (847) 367-8981

www.carter-hoffmann.com



Printed in U.S.A. B07 0205
Carter-Hoffmann is a trademark of Carter-Hoffmann Corp.

SPECIFICATIONS

FEATURES & BENEFITS

1551 McCormick Avenue, Mundelein, Illinois 60060
 Tel. (847)362-5500 • (800)323-9793 • Fax (847)367-8981
www.carter-hoffmann.com



BR SERIES ENDURAHEAT™ BANQUET CARTERS

Since 1947, Foodservice Equipment That Delivers!

DOUBLE WALL STAINLESS STEEL CABINET... Strongest, most durable materials for long life. High density 2" thick fiberglass insulation in walls, top, floor and doors for maximum heat retention.

HEAVY-DUTY STAINLESS STEEL BASE FRAME... 12 gauge caster bolsters with perimeter frame for rugged use and added durability.

NON-MARKING BUMPER SET IN HEAVY-DUTY 3/16" THICK EXTRUDED ALUMINUM FRAME... Protects doorways, walls and cart from damage. Reinforced with 12 gauge angle brackets for added strength.



BR120

COMPLETELY WELDED TURNED-IN SEAM CONSTRUCTION... Adds rigidity to entire cabinet and eliminates raw edges for ease of cleaning and safety.

WELDED, DUPLEX NICKEL-PLATED REMOVABLE WIRE SHELVES WITH REINFORCED SHELF CLIPS... Wires run from front to back for easier plate loading and unloading.

BALLOON TREAD CASTERS WITH SEALED ROLLER BEARING... Long lasting and easy rolling for maximum load and minimum maintenance. Mounted to base in offset wheel-ahead pattern for easy rolling.

HIGH PERFORMANCE HEATER... Blower system for fast heat up, recovery and even heat distribution throughout cabinet. One hour EnduraHeat charge/preheat time. 20 Minute preheat in convection mode. Toggle switch to select convected heat or EnduraHeat with indicator lights and EnduraHeat ready light. Simple dial controls for setting temperature. Removable without tools for easy cleaning.

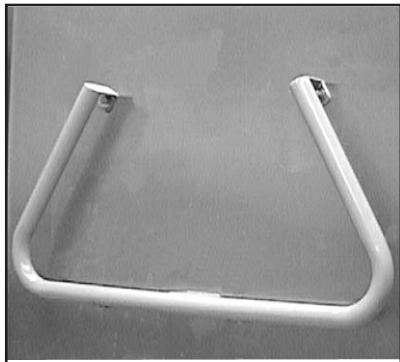

ERGONOMIC PUSH HANDLES... 1" Tubular stainless steel mounted to cabinet with backup plates. Designed for comfort grip and easy steering.



HEAVY-DUTY 1" STAINLESS STEEL TUBULAR HINGE... Full length eliminates torque on top hinge. Mounted with 1" bushing and 12 gauge stainless steel mounting bracket. Keeps doors properly aligned and withstands rugged use.



ERGONOMIC DOOR HANDLES WITH ROLLER LATCH... Stainless steel tubular handle for comfortable grip. Mounted with backup plates for added durability. Roller latch design has been a proven performer for over 10 years.

