

Unit Information

1 HP Motor
 1750 RPM's
 660 watts – 5.5 Amps
 5 Year Motor 2 Year Parts

Batch Bowl

Holds 2.5 quarts dry ingredients
 Holds 1.5 quarts wet ingredients

Continuous Feed

Can process 700 servings in 2.5 hours
 Can process up to 700 lbs. per hour

WARING COMMERCIAL®

FP25

/batch bowl only

FP25C

/batch bowl & continuous feed bowl

(both current production units comes w/ serrated S-blade, BFP13, BFP33 and BFP29)
 (both older units came w/ serrated S-blade, BFP13, BFP21 and BFP29)

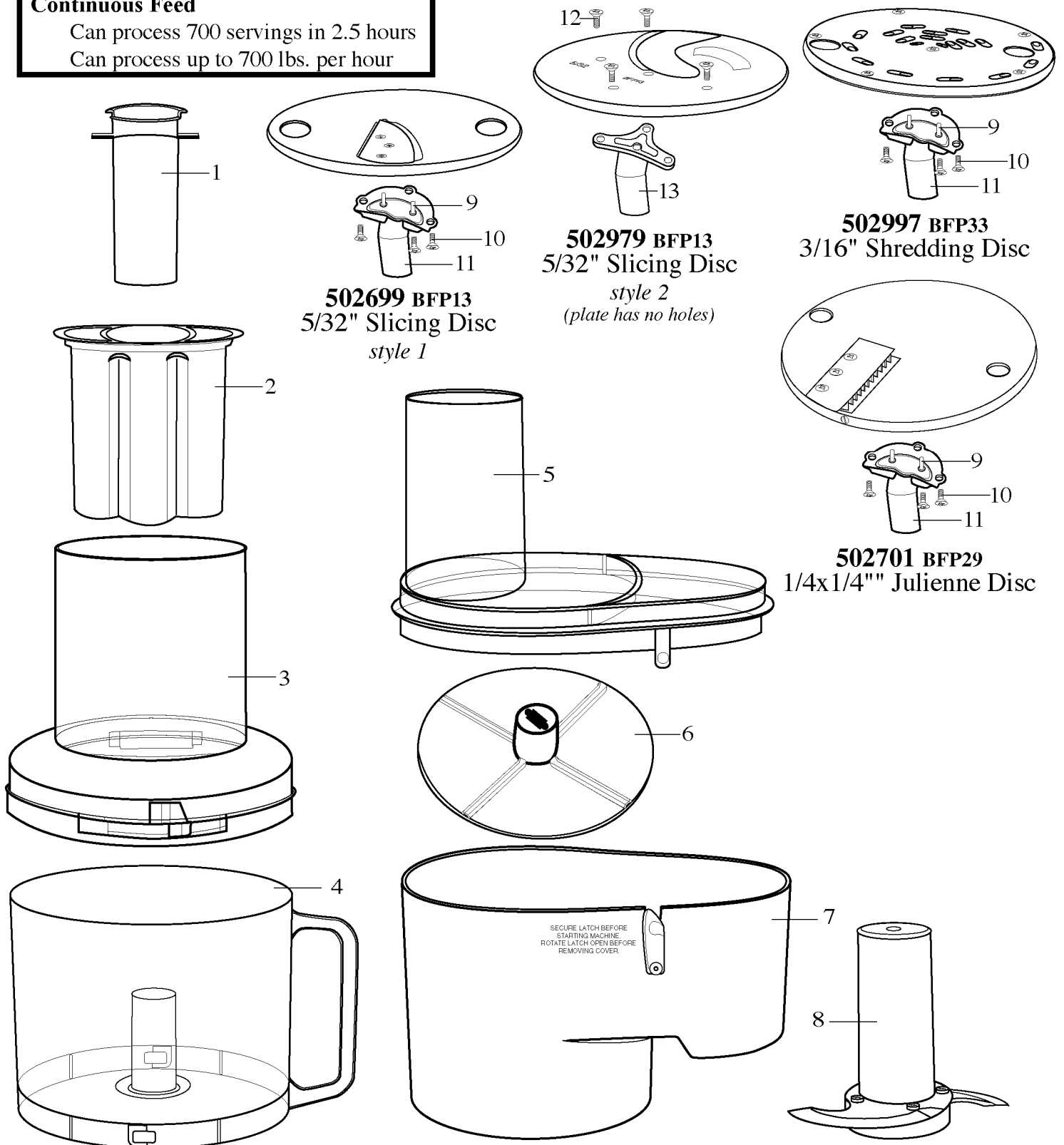

502699 BFP13
 5/32" Slicing Disc
 style 1

502979 BFP13
 5/32" Slicing Disc
 style 2
 (plate has no holes)

502997 BFP33
 3/16" Shredding Disc

502701 BFP29
 1/4x1/4" Julienne Disc

SECURE LATCH BEFORE
 STARTING MACHINE.
 ROTATE LATCH OPEN BEFORE
 REMOVING COVER.

WARING COMMERCIAL®

FP25 /batch bowl only

FP25C /batch bowl & continuous feed bowl

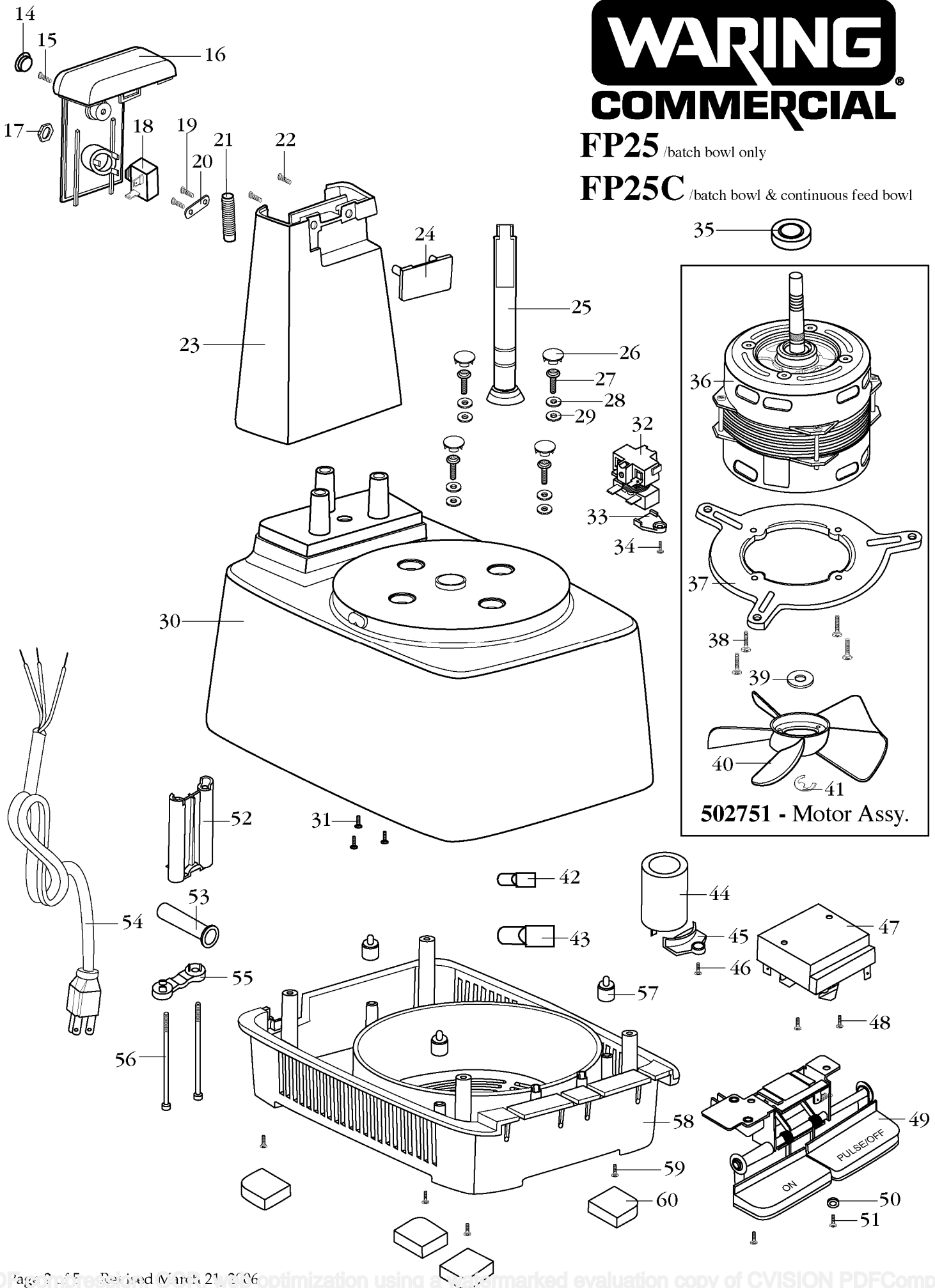

Model	Catalog
FP25	same
FP25C	same

Waring Factory Service Center
 314 Ella T. Grasso Ave.
 Torrington, CT 06790
 Tele. 1-800-269-6640

Fax 860-496-9017
 www.waringproducts.com



Illustration#	Part#	Description
1	025462	Small Pusher
2	025463	Large Pusher
3	025412	Batch Bowl Cover
4	025410	Batch Bowl
5	025411	Continuous Feed Cover
6	025477	Ejector Disc
7	025478	Continuous Feed Bowl
8	502691	S Blade Complete
9	025471	Disc Pin 2 Req.'d
10	024734	Screw 3 Req.'d
11	025472	Disc Stem
12	028342	Screw 4 Req.'d
13	028341	Stem
14	025479	Screw Plug
15	024750	Screw
16	025480	Tower Cover
17	025481	Nut
18	024745	Reset Switch
19	025482	Screw 2 Req.'d
20	024747	Retainer
21	024749	Magnetic Sensor
22	024750	Screw 2 Req.'d
23	025483	Tower
24	025484	Cover Latch Plate
25	025485	Motor Sheath with Sheath Cover
26	025486	Screw Plug 4 Req.'d
27	024756	Screw 4 Req.'d
28	024757	Washer 4 Req.'d

Model	Catalog
FP25	same
FP25C	same



Waring Factory Service Center
 314 Ella T. Grasso Ave.
 Torrington, CT 06790
 Tele. 1-800-269-6640
 Fax 860-496-9017
 www.waringproducts.com

Illustration#	Part#	Description
29	024759	Washer /fiber 4 Req.'d
30	025487	Upper Housing
31	025488	Screw 3 Req.'d
32	024763	Relay
33	024764	Relay Plate
34	024750	Screw
35	024766	Oil Seal
36	025872	Motor
37	024768	Motor Support
38	024769	Screw 4 Req.'d
39	024770	Washer /metal
40	024771	Fan
41	024772	E-Ring
42	012409	Small Crimp Connector 6 Req.'d
43	024789	Large Crimp Connector 2 Req.'d
44	024773	Capacitor
45	024774	Capacitor Plate
46	024750	Screw
47	024775	Sensor Relay
48	024762	Screw 2 Req.'d
49	025489	Switch
50	024779	Washer /ground wire
51	024762	Screw 2 Req.'d
52	025490	Cord Support Clamp
53	024781	Cord Bushing
54	024782	Cord
55	024783	Cord Clamp

Model	Catalog
FP25	same
FP25C	same

Waring Factory Service Center
 314 Ella T. Grasso Ave.
 Torrington, CT 06790
 Tele. 1-800-269-6640
 Fax 860-496-9017
 www.waringproducts.com

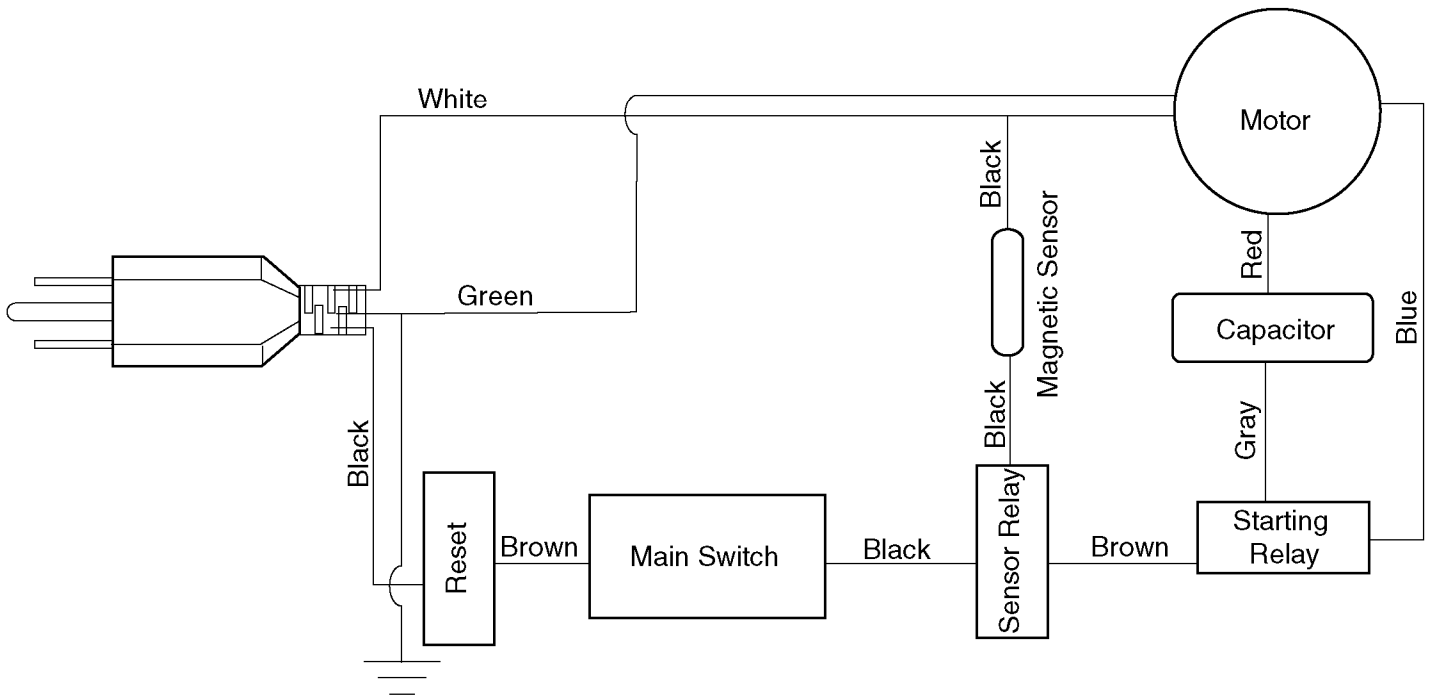
Illustration#	Part#	Description
56	024784	Screw 2 Req.'d
57	024785	Motor Pad 3 Req.'d
58	025491	Lower Housing
59	024762	Screw 4 Req.'d
60	024788	Foot 4 Req.'d



Wiring Diagram