

VULCAN

CATALOG OF REPLACEMENT PARTS

ELECTRIC CONVECTION OVENS

MODELS

<i>VC4ES</i>	<i>ML-126743</i>
<i>VC4ED</i>	<i>ML-126744</i>
<i>VC4EC</i>	<i>ML-126745</i>
<i>VC6ES</i>	<i>ML-126746</i>
<i>VC6ED</i>	<i>ML-126747</i>
<i>VC6EC</i>	<i>ML-126748</i>



For additional information on Vulcan-Hart or to locate an authorized parts and service provider in your area, visit our website at www.vulcanhart.com

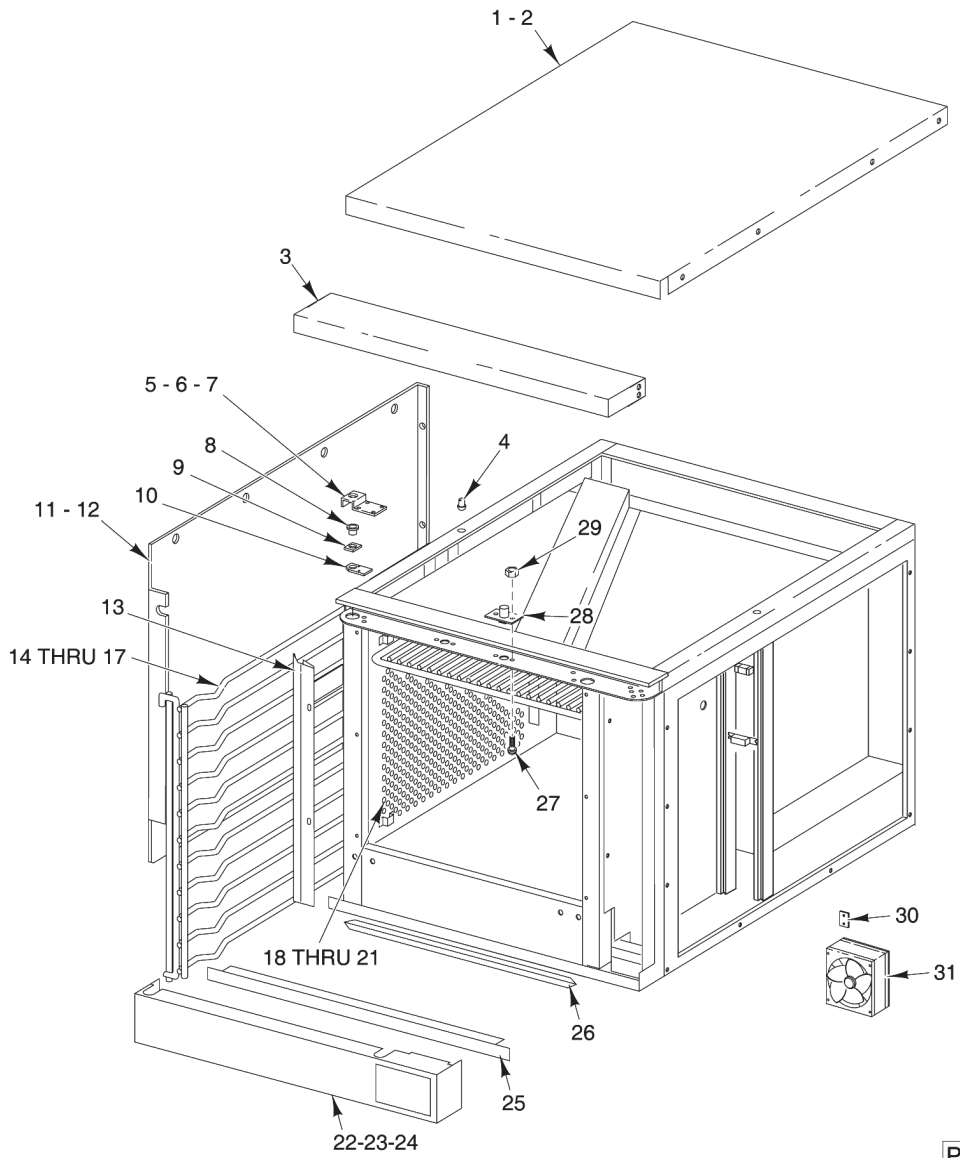

OVEN
(LH SIDE)

**OVEN
(LH SIDE)**

ILLUS.	PART NO.	NAME OF PART	AMT.
PL-55974A			
1	00-424141-00002	Top (SST) (VC4)	1
2	00-424229-00002	Top (SST) (VC6)	1
3	00-421799-00001	Top – Front	1
4	00-339337-00001	Stud – Locating (With Stacking Kit Only)	2
5	00-353484-00001	Plate – Retainer	2
6	SC-053-46	Mach. Screw 1/4-20 x 3/4 Truss Hd. (SST)	4
7	NS-038-08	Lock Nut 1/4-20 x 1 Hex Hd.	4
8	00-347080-00002	Bearing – Door Shaft	2
9	00-353482-00001	Spacer	2
10	00-353483-00001	Plate – Upper Door Bearing	2
11	00-424142-00002	Panel – Outer (SST) (LH) (VC4)	1
12	00-424230-00002	Panel – Outer (SST) (LH) (VC6)	1
13	00-423842-000G1	Seal – Vertical Door (LH or RH)	1
14	00-342141-00001	Rack – Support (LH) (VC4)	1
15	00-342141-00002	Rack – Support (RH) (VC4)	1
16	00-424833-00001	Rack – Support (LH) (VC6)	1
17	00-424833-00002	Rack – Support (RH) (VC6)	1
18	00-426648-000G1	Cavity – Side Assy. (LH) (VC4)	1
19	00-426920-000G1	Cavity – Side Assy. (LH) (Porcelain) (VC6)	1
20	00-426648-000G2	Cavity – Side Assy. (RH) (VC4)	1
21	00-426920-000G2	Cavity – Side Assy. (RH) (Porcelain) (VC6)	1
22	00-423766-000G1	Trim – Bottom (Incls. Items 24 & 25)	1
23	00-423758-00001	Access Door	1
24	00-425199-00001	Fastener – Nylon (Push-In)	2
25	00-424865-00001	Cover – Trim	1
26	00-357507-00001	Seal – Horizontal Door (30 1/2 Lg.) (Top or Bottom)	2
27	SC-115-51	Mach. Screw – 10-32 x 1/2 Phil. Truss Hd.	4
28	00-347545-00001	Plate – Door Catch	2
29	NS-038-03	Locknut – SP 10-32	4
30	00-425433-00001	Fan – Clip	1
31	00-424940-00002	Fan – Cooling (230 V.)	1
	00-346357-00001	Thermostat – Hi Limit (Thermodisc)	1
	00-357919-00001	Flexible Door Seal Kit	1

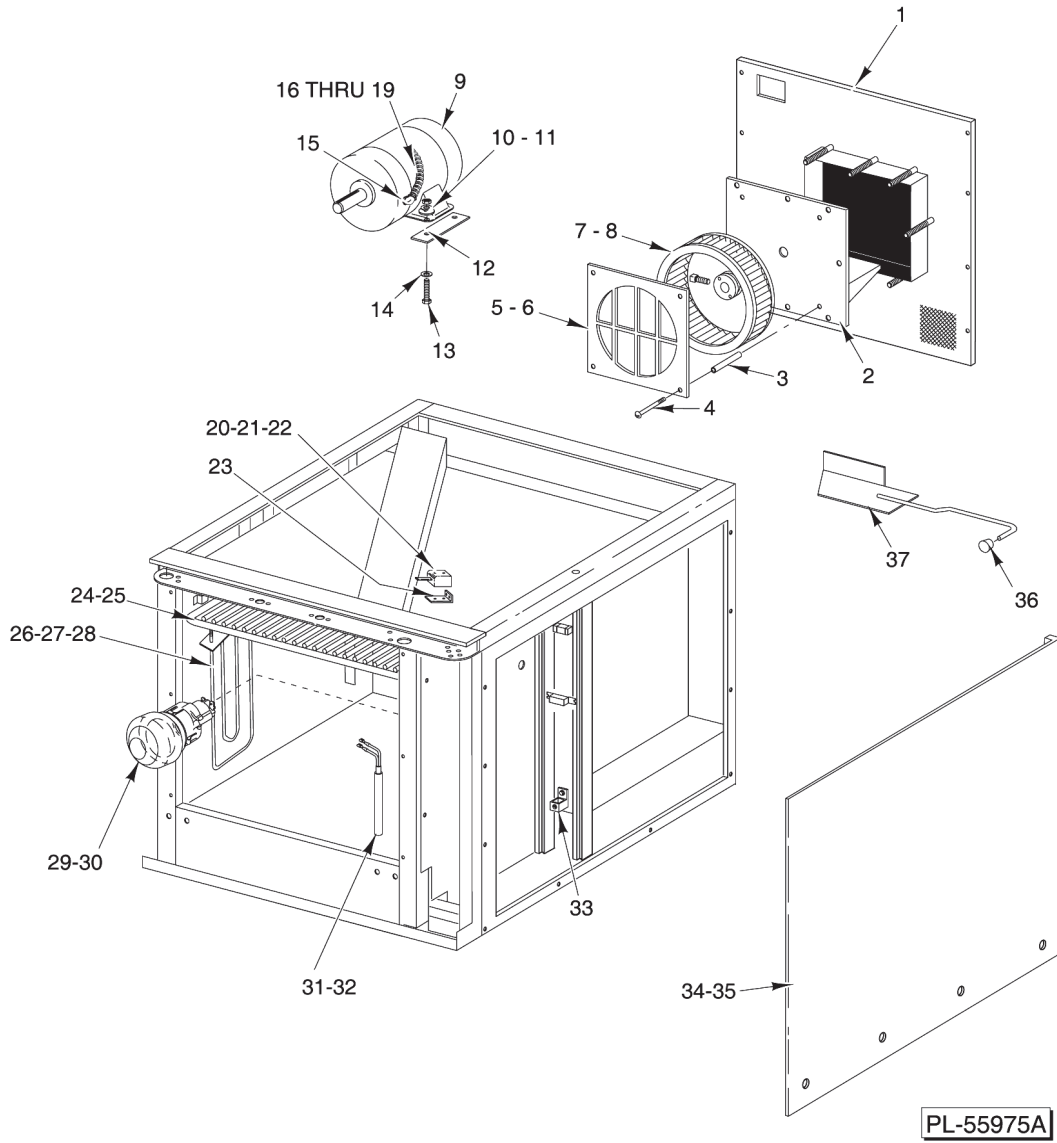

**OVEN
(RH SIDE)**

**OVEN
(RH SIDE)**

ILLUS. PL-55975A	PART NO.	NAME OF PART	AMT.
1	00-426839-000G1	Back – Panel Assy.	1
2	00-423289-000G1	Motor Mount	1
3	00-411289-00004	Spacer – Fan Housing	4
4	SC-120-15	Mach. Screw 1/4-20 x 4 Rd. Hd.	4
5	00-411136-00004	Cover – Fan (60 Hz.)	1
6	00-411136-00003	Cover – Fan (50 Hz.)	1
7	00-415780-00003	Wheel – Blower (60 Hz.)	1
8	00-415780-00005	Wheel – Blower (50 Hz.)	1
9	00-358516-00002	Motor 1/2 Hp. (2 Speed) (208-240/50/60/1)	1
10	WS-029-46	Washer	4
11	NS-046-86	Nut Assy. 5/16-18 KEPS Hex	4
12	00-358723-00001	Spacer – Steel	2
13	SC-113-65	Cap Screw 5/16-18 x 1 1/4 Hex Hd.	4
14	WS-029-46	Washer	4
15	FE-002-52	Connector – Conduit 3/8 TS (90 Deg.)	1
16	FE-006-05	Lock Nut 1/2	1
17	00-414540-00B35	Conduit 3/8 x 35 Lg.	1
18	00-342285-00001	Bushing – Plastic	2
19	FE-002-03	Connector – Conduit 3/8 TS Straight	1
20	00-411496-000F1	Switch – Micro	1
21	NS-038-08	Lock Nut 1/4-20 Hex	2
22	WS-029-49	Washer	2
23	00-425324-00001	Bracket – Door Switch	1
24	00-423816-000G1	Rack Assy. (VC4)	AR
25	00-423816-000G2	Rack Assy. (VC6)	AR
26	00-426635-00001	Element – (2000 W.) (208 V.)	6
27	00-426635-00002	Element – (2000 W.) (240 V.)	6
28	00-426635-00003	Element – (2000 W.) (480 V.)	6
29	00-357036-00001	Oven Lamp (40 W.) (120-130 V.)	2
30	00-423832-00001	Cover – Light (Metal)	2
31	00-353589-00001	Probe (“D” Models)	1
32	00-920883-00003	Probe (“C” Models)	1
33	00-417856-00001	Lug – Grounding (With Set Screw)	1
34	00-424140-00002	Panel – Exterior (RH) (VC4) (SST)	1
35	00-424228-00002	Panel – Exterior (RH) (VC6) (SST)	1
36	00-341564-00003	Handle	1
37	00-426804-000G1	Vent Slide Assy. (Incls. Item 38)	1
	00-423818-000G7	Pan – Drip (VC4)	1
	00-423818-000G8	Pan – Drip (VC6)	1
	00-357036-00003	Glass Lamp Lens	1

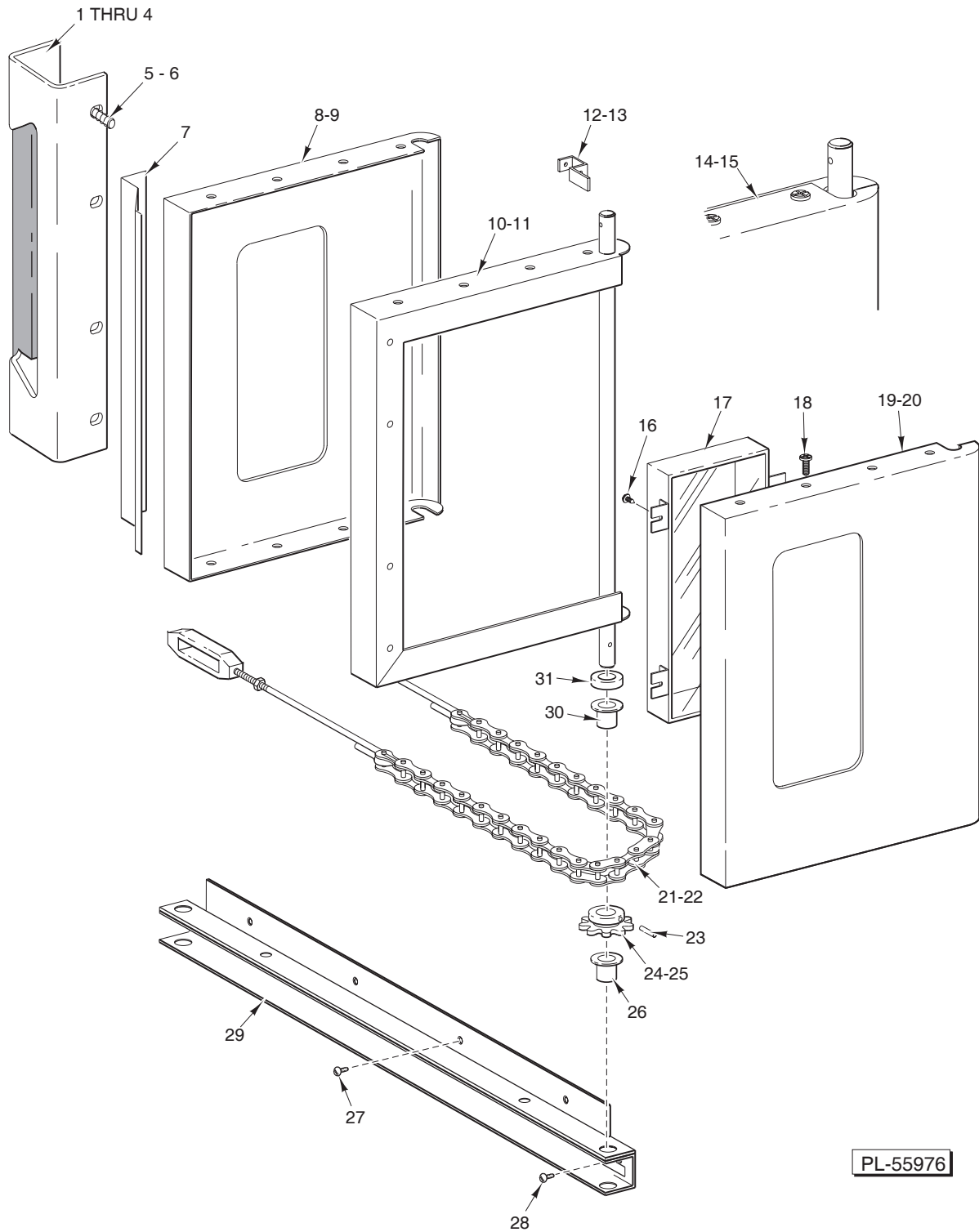

PL-55976

**DOOR ASSEMBLY
(SIMULTANEOUSLY OPENING DOORS)**

**DOOR ASSEMBLY
(SIMULTANEOUSLY OPENING DOORS)**

ILLUS. PL-55976	PART NO.	NAME OF PART	AMT.
1	00-356562-00001	Handle – Door	1
2	00-356563-00003	Grip – Front	1
3	00-356563-00004	Grip – Rear	1
4	SC-113-98	Mach. Screw 10-24 x 1/2 Hex Washer Hd.	3
5	SC-041-01	Cap Screw 1/4-20 x 3/4 Hex Hd. (SST)	4
6	WL-019-37	Lockwasher 1/4 Internal	4
7	00-356550-00001	Latch – Friction	1
8	00-421913-00003	Shell – Outer Door (LH) (W/Window)	1
9	00-421913-00001	Shell – Outer Door (RH) (W/Window)	1
10	00-421904-000G1	Frame Assy. – Door (LH)	1
11	00-421905-000G1	Frame Assy. – Door (RH)	1
12	00-424163-00001	Lever – Door Switch	1
13	SD-034-52	Self-Tapping Screw 8-32 x 1 Hex Washer Hd., Type T	1
14	00-424730-00001	Door Assy. (LH) (W/Window)	1
15	00-424731-00001	Door Assy. (RH) (W/Window)	1
16	SD-034-62	Self-Tapping Screw 10-32 x 1/2 Hex Washer Hd., Type T	4
17	00-358534-00001	Window Assy.	1
18	00-350543-00006	Mach. Screw 10-32 x 1/2 Phil. Pan Hd.	9
19	00-358532-00001	Shell – Inner Door (LH) (W/Window)	1
20	00-358532-00002	Shell – Inner Door (RH) (W/Window)	1
21	00-343608-00002	Door Chain & Turnbuckle Assy.	2
22	00-352667-00001	Cable – Door Stop	1
23	PS-004-11	Spiral Pin 3/16 x 1 1/4	2
24	00-342166-00001	Sprocket – Door Shaft	2
25	SC-047-28	Set Screw 1/4-28 x 3/8 Hex Hdls., Cup Pt.	2
26	00-347080-00002	Bearing – Door Shaft	2
27	SC-022-40	Mach. Screw 1/4-20 x 3/4 Phil. Flat Hd.	4
28	SC-113-90	Mach. Screw 1/4-20 x 3/4 Hex Hd.	2
29	00-357846-00001	Channel – Door Sill Weldment	1
30	00-347080-00002	Bearing – Door Shaft Warmer	2
31	00-343143-00002	Washer	2
	00-520228	Adhesive – Loctite 242 (Use W/Item 25) (50 cc Bottle)	AR

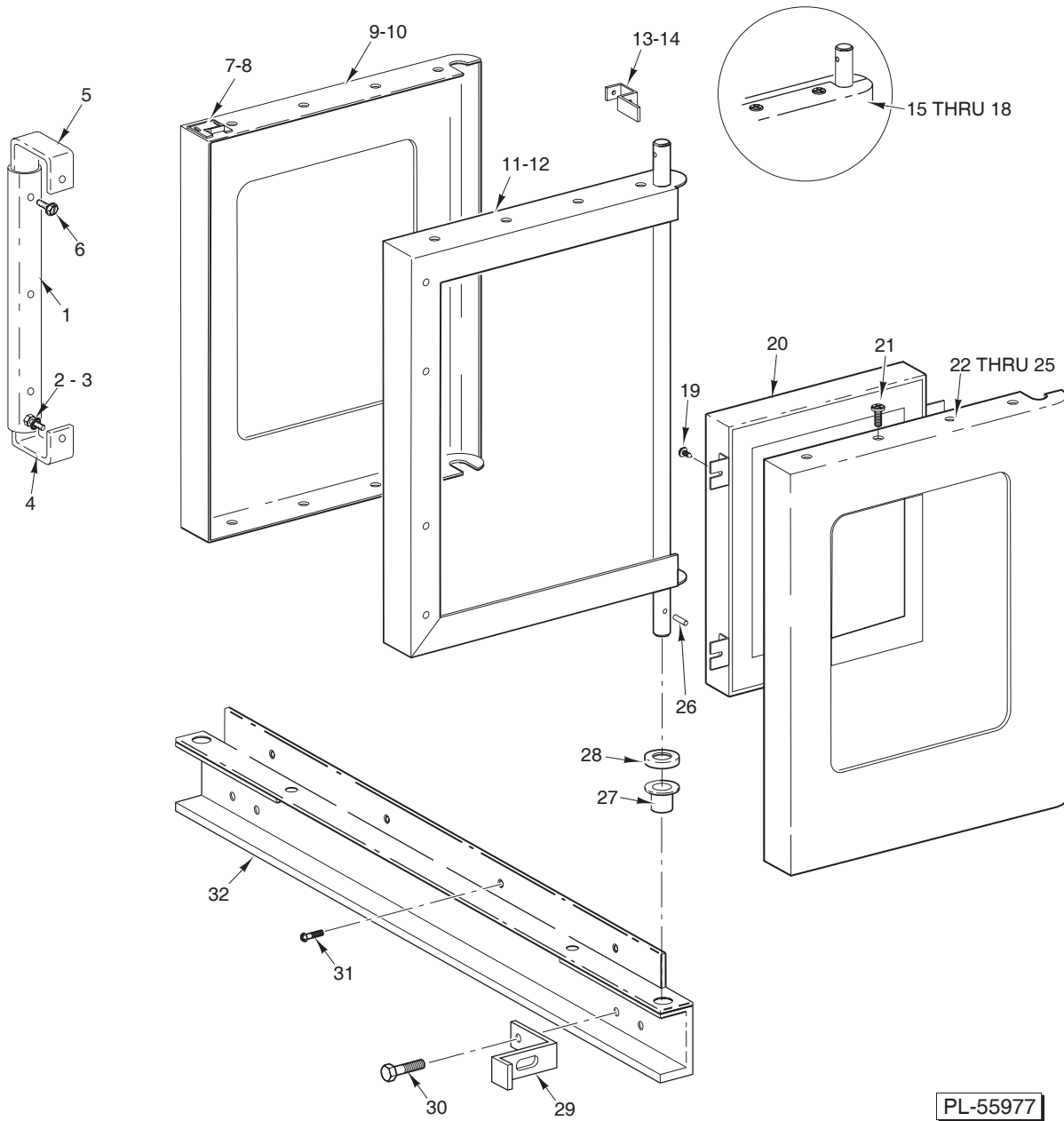

**DOOR ASSEMBLY
(INDEPENDENTLY OPENING DOORS)**

**DOOR ASSEMBLY
(INDEPENDENTLY OPENING DOORS)**

ILLUS. PL-55977	PART NO.	NAME OF PART	AMT.
1	00-357929-00002	Handle – Door	1
2	SC-041-01	Cap Screw 1/4-20 x 3/4 Hex Hd. (SST) (Prior to November 2005)	2
3	WL-019-37	Lockwasher 1/4 Internal (Prior to November 2005)	2
4	00-358728-00001	Handle – End Piece (Prior to November 2005)	1
5	00-358728-00001	Handle – End Piece (Prior to November 2005)	1
6	SC-113-98	Mach. Screw 10-24 x 1/2 Hex Washer Hd.	3
7	00-423847-00001	Strike – Door	1
8	00-350543-00006	Mach. Screw 10-32 x 1/2 Phil. Pan Hd.	2
9	00-358600-00001	Shell – Outer Door (RH) (W/Window)	1
10	00-358600-00002	Shell – Outer Door (RH) (W/O Window) (Not Shown)	1
11	00-421905-000G1	Frame Assy. – Door (RH)	1
12	00-421904-000G1	Frame Assy. – Door (LH)	1
13	00-424163-00001	Lever – Door Switch	1
14	SD-034-52	Self-Tapping Screw 8-32 x 1 Hex Washer Hd., Type T	1
15	00-358529-00005	Door Assy. (LH) (W/Window)	1
16	00-358529-00006	Door Assy. (LH) (W/O Window)	1
17	00-358530-00003	Door Assy. (RH) (W/Window)	1
18	00-358530-00004	Door Assy. (RH) (W/O Window)	1
19	SD-034-62	Self-Tapping Screw 10-32 x 1/2 Hex Washer Hd., Type T	4
20	00-358534-00001	Window Assy.	1
21	00-350543-00006	Mach. Screw 10-32 x 1/2 Phil. Pan Hd.	8
22	00-358532-00002	Shell – Inner Door (RH) (W/Window)	1
23	00-358532-00001	Shell – Inner Door (LH) (W/Window)	1
24	00-358533-00004	Shell – Inner Door (Solid) (RH) (W/O Window)	1
25	00-358533-00003	Shell – Inner Door (Solid) (LH) (W/O Window)	1
26	PS-004-11	Spiral Pin 3/16 x 1 1/4	1
27	00-347080-00002	Bearing – Door Shaft	1
28	00-343143-00002	Washer	2
29	00-424158-00001	Door Stop	1
30	SC-113-90	Mach. Screw 1/4-20 x 3/4 Hex Hd.	2
31	SC-022-40	Mach. Screw 1/4-20 x 3/4 Phil. Flat Hd.	4
32	00-357846-00001	Channel – Door Sill Weldment	1
	00-357837-00001	Door End Seal (LH)	1

ELECTRIC CONVECTION OVENS REPLACEMENT PARTS

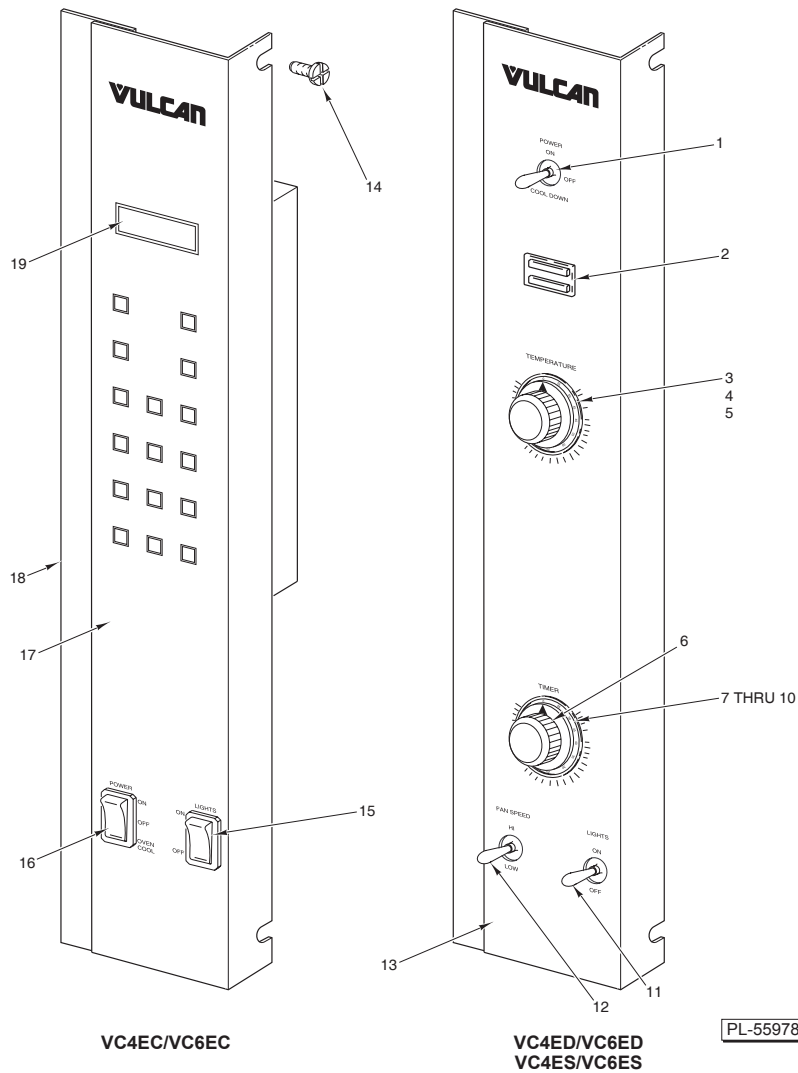

PL-55978

CONTROL PANEL

ILLUS.	PART NO.	NAME OF PART	AMT.
PL-55978			
1	00-340324-00008	Switch (Hold)	1
2	00-354575-00001	Light – Indicator (On/Heat) (200-240 V.)	1
3	00-411242-00001	Knob	1
4	00-353613-00002	Controller – Temperature (SS) (500 Deg.) (“D” Model)	1
5	00-411506-00003	Thermostat (“S” Model) (Prior to 02/2001)	1
6	00-411242-00001	Knob	1
7	00-411690-00002	Timer (240 V.) (1 Hr.) (60 Hz.)	1
8	00-411690-00004	Timer (240 V.) (5 Hr.) (60 Hz.)	1
9	00-411690-00005	Timer (240 V.) (1 Hr.) (50 Hz.)	1
10	00-411690-00006	Timer (240 V.) (5 Hr.) (50 Hz.)	1
11	00-340324-00012	Switch (S.P.S.T.)	1
12	00-340324-00009	Switch (D.P.D.T.)	1
13	00-426719-00001	Overlay – Panel (“S” Model)	1
	00-426855-00001	Overlay – Control Panel (“D” Model)	1
14	SD-037-02	Self-Tapping Screw 10-16 x 1/2 Hex Washer Hd., Type AB	3
15	00-358628-00002	Switch – Rocker (2 Position)	1
16	00-358628-00001	Switch – Rocker (3 Position)	1
17	00-426930-00001	Overlay – Control Panel	1
18	00-424842-000G1	Control Panel Weldment (“C” Model)	1
19	00-424846-00001	Controller (Watlow #734) (“C” Model)	1
	00-411499-00003	Buzzer (230 V.)	1
	00-423918-00001	Electronic Beeper	1
	00-426206-000G1	Control Panel Weldment (“D” and “C” Models)	1

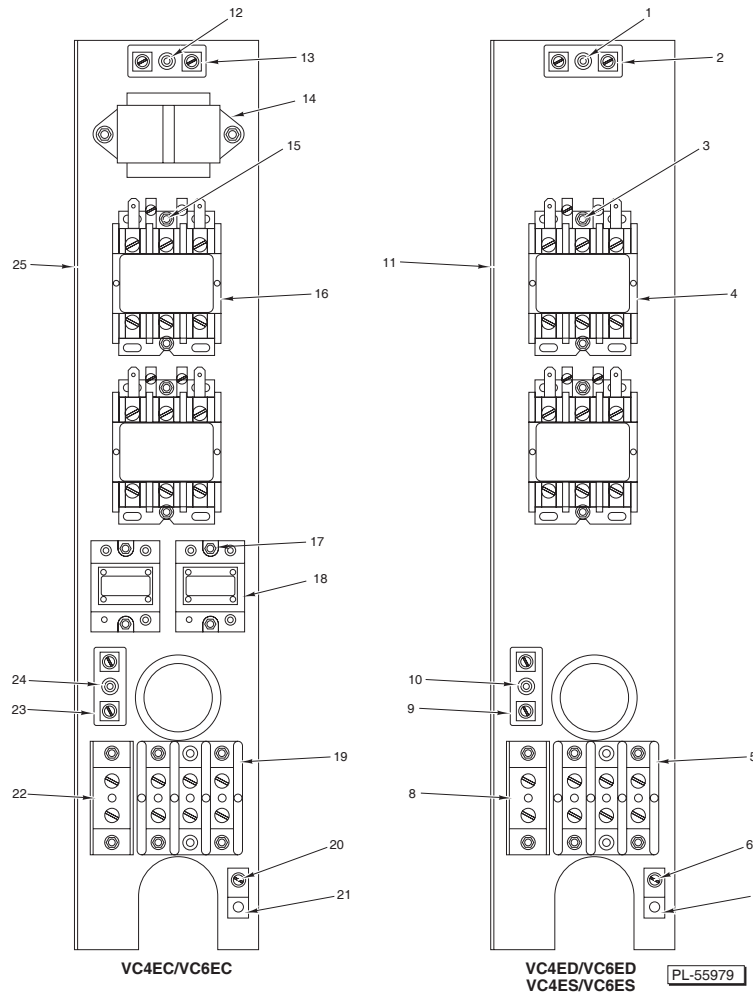

COMPONENT PANEL

ILLUS.	PART NO.	NAME OF PART	AMT.
	PL-55979		
1	SD-034-52	Self-Tapping Screw 8-32 x 1 Hex Washer Hd., Type T	1
2	00-417934-000G1	Porcelain – Block Assy.	1
3	SD-032-07	Self-Tapping Screw 10-24 x 1/2 Hex Washer Hd., Type TT	4
4	00-411497-000C5	Contactor (3 Pole)	2
5	00-410472-00008	Terminal Block	1
6	SD-032-07	Self-Tapping Screw 10-24 x 1/2 Hex Washer Hd., Type TT	1
7	00-417856-00001	Lug – Grounding (With Set Screw)	1
8	00-410472-00009	Block – Terminal (1 Pole)	1
9	00-417934-000G1	Porcelain – Block Assy.	1
10	SD-034-52	Self-Tapping Screw 8-32 x 1 Hex Washer Hd., Type T	1
11	00-422155-00001	Component Panel	1
12	SD-034-52	Self-Tapping Screw 8-32 x 1 Hex Washer Hd., Type T	1
13	00-417934-000G1	Porcelain – Block Assy.	1
14	00-421758-000G2	Transformer (208-240 V.) (Prior to November 11, 2002)	1
	00-421758-000G4	Transformer Assy. (November 11, 2002 to Present)	1
15	SD-032-07	Self-Tapping Screw 10-24 x 1/2 Hex Washer Hd., Type TT	4
16	00-411497-000C5	Contactor (3 pole)	2
17	SD-034-52	Self-Tapping Screw 8-32 x 1 Hex Washer Hd., Type T	4
18	00-821875-00002	Relay – Solid State (50 Amp.)	2
19	00-410472-00008	Terminal Block	1
20	SD-032-07	Self-Tapping Screw 10-24 x 1/2 Hex Washer Hd., Type TT	1
21	00-417856-00001	Lug – Grounding (With Set Screw)	1
22	00-410472-00009	Block – Terminal (1 Pole)	1
23	00-417934-000G1	Porcelain – Block Assy.	1
24	SD-034-52	Self-Tapping Screw 8-32 x 1 Hex Washer Hd., Type T	1
25	00-422155-00001	Component Panel	1

RECOMMENDED SPARE PARTS

PART NO.	NAME OF PART	AMT.
00-353589-00001	Probe ("D" Model)	2
00-340324-00009	Switch (D.P.D.T.) (Fan Speed) (Toggle)	2
00-340324-00012	Switch (S.P.S.T.) (Lights) (Toggle)	2
00-358628-00002	Rocker Switch Lights	2
00-424940-00002	Cooling Fan (240V)	2
00-353613-00002	Temperature Control ("D" Model)	2
00-411242-00001	Control Knob	2
00-411690-00002	Timer (1 Hour) (240V)	2
00-411499-00003	Buzzer	2
00-411496-000F1	Door Switch	2
00-346357-00001	High Limit	2
00-411497-000C5	Contactora (3-pole)	2
00-340324-00008	Toggle Switch (ON/OFF)	2
00-411500-00013	Transformer (240V/24V) (40VA)	2
FE-023-55	Fuse Holder	4
FE-019-40	Fuse (15-amp)	4
00-426635-00001	Element (208V)	2
00-426635-00002	Element (240V)	2
00-426635-00003	Element (480V)	2
00-821875-00002	SST Relay (50-amp)	2
00-920883-00003	Temperature Probe Computer	2
00-424846-00001	Computer Controller (Watlow)	AR
00-358516-00002	Blower Motor (2-speed, 1/3 HP)	AR
00-358628-00001	ON/OFF Cool Down Switch Computer	2
00-357036-00001	Oven Lamp Assy.	1
00-411506-00003	KX Thermostat ("S" Model) (Prior to 2001)	2