

Operator's Manual

CAYENNE HOT DOG ROLLER GRILL



Item	Description	Number of Rollers	Watts	Voltage	Amps	Plug
40820	Hot Dog Roller Grill	5	400	120V	3.3	5-15P
40821	Hot Dog Roller Grill	7	560	120V	4.7	5-15P
40822	Hot Dog Roller Grill	9	720	120V	6.0	5-15P

Thank you for purchasing this Vollrath equipment. Before operating the equipment, read and familiarize yourself with the following operating and safety instructions. **SAVE THESE INSTRUCTIONS FOR FUTURE REFERENCE.** Save the original box and packaging. Use this packaging to ship the equipment if repairs are needed.

SAFETY PRECAUTIONS

To ensure safe operation, read the following statements and understand their meaning. Please read carefully.

WARNING

Warning is used to indicate the presence of a hazard that *can* cause *severe* personal injury, death, or substantial property damage if the warning is ignored.

CAUTION

Caution is used to indicate the presence of a hazard that *will* or *can* cause *minor* personal injury or property damage if the caution is ignored.

NOTE

Note is used to notify people of installation, operation, or maintenance information that is important but not hazard-related.

For Your Safety!

These precautions should be followed at all times. Failure to follow these precautions could result in injury to yourself and others.

To reduce risk of injury or damage to the equipment:

- Use only grounded electrical outlets matching the nameplate rated voltage.
- Have equipment installed by a qualified personnel in accordance with local codes and ordinances.
- Use equipment in a flat, level position.
- Do not use an extension cord with this equipment. Do not plug this equipment into a power strip or multi-outlet power cord.
- Unplug equipment, turn off and let it cool before cleaning or moving.
- Do not spray controls or outside of equipment with liquids or cleaning agents.
- Do not clean equipment with steel wool.
- Keep equipment and power cord away from open flames, electric burners or excessive heat.
- Do not operate unattended.
- Do not operate equipment in public areas and/or around children.
- The equipment may be hot, even though the pilot light is not on.
- Do not operate if equipment has been damaged or is malfunctioning in any way.
- Depending upon the usage and local ordinances It may be necessary to use the breath guard accessory. Check with local ordinances for rules on use. This accessory is available through a Vollrath authorized sales agent. Visit Vollrathco.com for more information.

FUNCTION AND PURPOSE

This equipment is intended to warm precooked foods and hold at proper serving temperature. It is not intended or designed to cook raw food.

Before using this equipment it must be cleaned and dried thoroughly.

This grill is a medium duty appliance capable of grilling a wide variety of sausages. The temperature of the roller is controlled by the thermostat control on the front of the equipment. The main switch operates the motor and allows the heating elements to be energized.

UNPACKING THE EQUIPMENT AND INITIAL SETUP

When no longer needed, dispose of all packaging and materials in an environmentally responsible manner.

1. Remove all packing material and tape, as well as any protective plastic from the equipment.
2. Clean any glue residue left over from the plastic or tape.
3. Place the equipment in the desired position and height.
4. Plug equipment into a properly grounded electrical supply matching the nameplate rating. Damage to the equipment can occur if incorrect power is supplied to equipment.

FEATURES AND CONTROLS

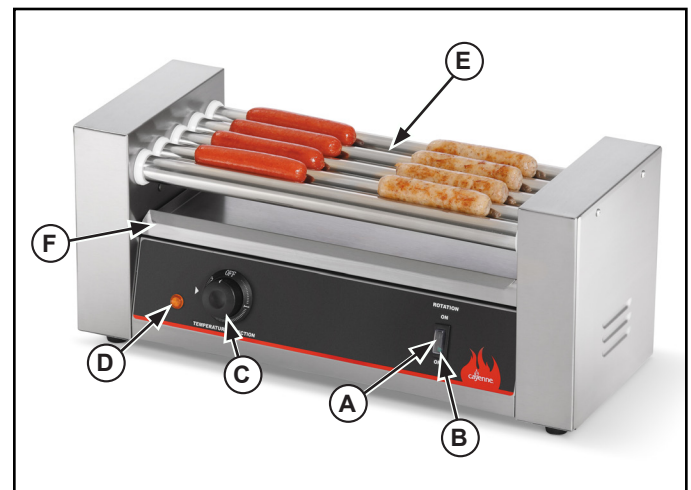



Figure 1. Features and Controls.

- (A) POWER SWITCH. Switches the rollers and power to the elements ON or OFF.
- (B) POWER INDICATOR LIGHT. Illuminates when the power switch has been turned on.
- (C) THERMOSTAT CONTROL dial. Used to set or adjust the temperature of the elements.
- (D) PILOT LIGHT. This light indicates that the surface is heating. Once the set temperature has been reached the light will go out. Equipment will continue to maintain heat and temperature with the light cycling on and off. This is not a power indicator light.
- (E) ROLLERS. These turn during operation and rotate the food product.
- (F) DRIP TRAY. A container under the rollers that collects grease and oil from the warming process.
- (G) BREATH GUARD (not shown). Covers the food product during the warming process and product display.



OPERATION

	WARNING
	Burn Hazard. Do not touch hot food, liquid or heating surfaces while equipment is heating or operating.
Hot surfaces and food can burn skin. Allow the hot surfaces to cool before handling. Do not drop or spill water onto the cooking surface as it can spray or splatter.	

Before initial use, turn the thermostat control to the maximum setting, and allow equipment to burn-in for 30 minutes. You may notice smoke appearing due to the cooking surface burning-in. This is normal. After 30 minutes the equipment is ready for use.

1. If using a breath guard put into place at this time. Orientate in such a way that the door side faces the operator.
2. Set the drip tray (F) in place. See Figure 1.
3. Switch the power switch (A) to the ON position.
4. Turn thermostat control (C) to desired temperature setting and preheat for 15 minutes.
5. Set precooked food product onto the rollers (E).

Food Safety Precautionary Note:

Monitor food temperature closely for food safety. The United States Public Health Service recommends that hot food be held at a minimum of 140 °F (60 °C) to help prevent bacteria growth.

6. Switch the power switch (A) to the OFF position.
7. Remove the food product and discard or properly store as guided by the instructions of the food product manufacturer.
8. Clean after each use cycle following the CLEANING Section in this manual.

CLEANING

To maintain the appearance and increase the service life, clean your equipment daily.

	WARNING
	Burn Hazard. Do not touch hot food, liquid or heating surfaces while equipment is heating or operating.
Hot surfaces and food can burn skin. Allow the hot surfaces to cool before handling. Do not drop or spill water into the cooking surface as it can spray or splatter.	

	WARNING
	Electrical Shock Hazard. Keep water and other liquids from entering the inside of the equipment. Liquid inside the equipment could cause an electrical shock.
Do not spray water or cleaning products. Liquid could contact the electrical components and cause a short circuit or an electrical shock. Do not use equipment if power cord is damaged or has been modified	

NOTE:

Do not clean the equipment with steel wool. Do not immerse the cord, plug or equipment in water or any other liquid. Do not use high pressure washer to clean this equipment.

9. Switch the power switch (A) to the OFF position. See Figure 1.
 1. Allow the equipment to cool completely before cleaning.
 2. Unplug the equipment.
 3. Wipe the rollers (E) with a clean dry cloth. See Figure 1.
 4. Using a damp cloth, sponge dipped in soapy water, wipe the outside of the equipment.
 5. To clean the breath guard use a damp cloth, sponge dipped in soapy water. Do not use ammonia based cleaners. Do not use abrasive materials, scratching cleansers or scouring pad to clean the unit. These can damage the finish.
 6. Dry thoroughly after cleaning.
 7. Remove, empty and clean the drip tray (F). Place the drip tray into the equipment.

TROUBLESHOOTING

Problem	It might be caused by	Course of Action
Pilot Light does not come on when the temperature control is turned up.	The equipment is not plugged in.	Plug equipment in.
	Pilot Light malfunction.	Replace Pilot Light.
The light comes on, equipment does not heat.	Thermostat Control malfunction.	Replace Thermostat Control.
	Heating Element malfunction.	Replace Heating Element.

SERVICE AND REPAIR

There are no user serviceable parts within this appliance. To avoid serious injury or damage, never attempt to repair the equipment or replace a damaged power cord yourself. Do not send equipment directly to the Vollrath Company. Please contact the qualified professional repair service listed below.

VOLLRATH Technical Service • 1-800-628-0832

8.

ELECTRICAL DRAWING - HOT DOG ROLLER GRILL

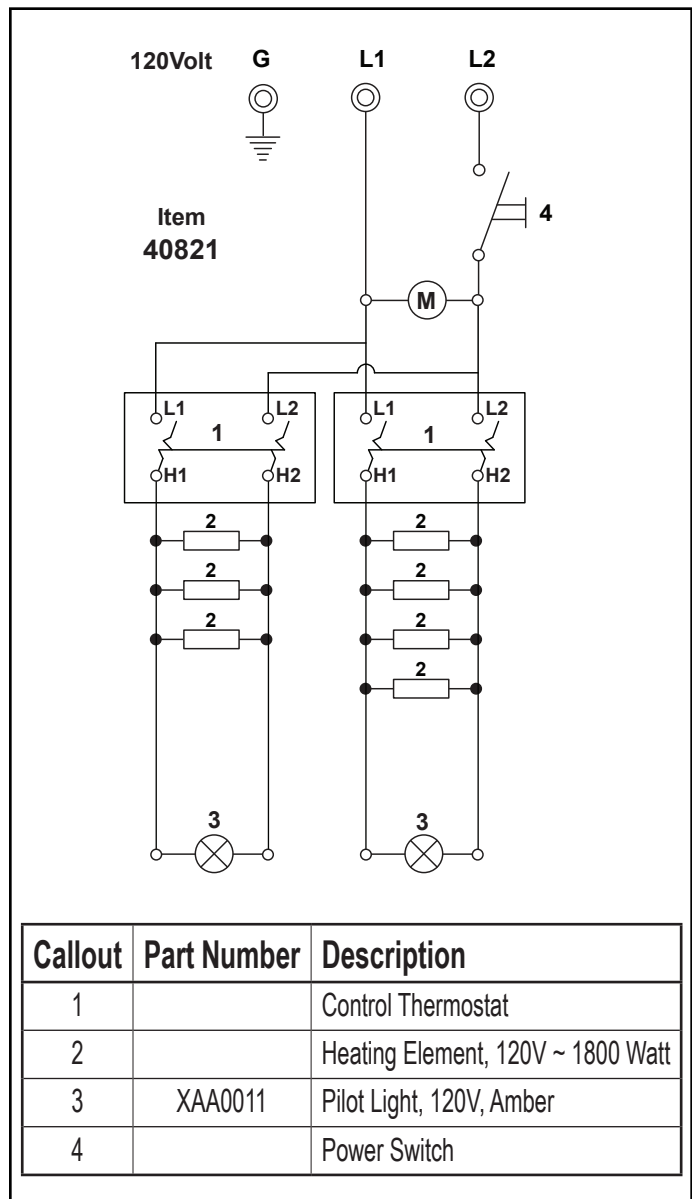
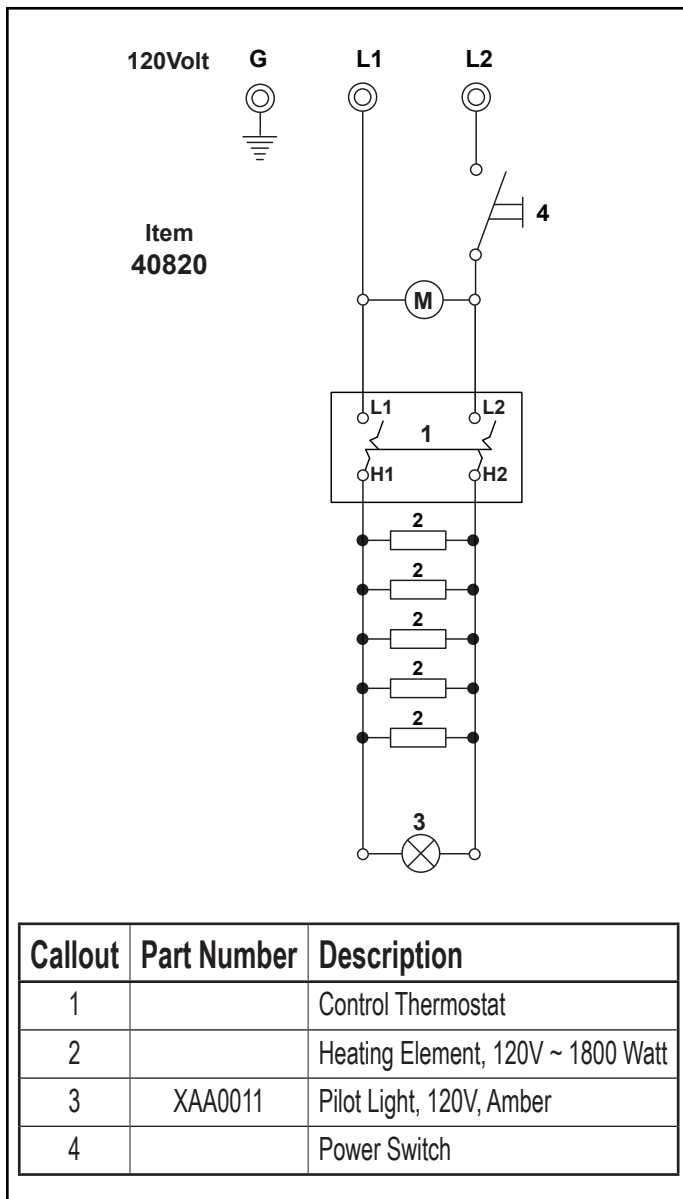

ELECTRICAL DRAWING - HOT DOG ROLLER GRILL

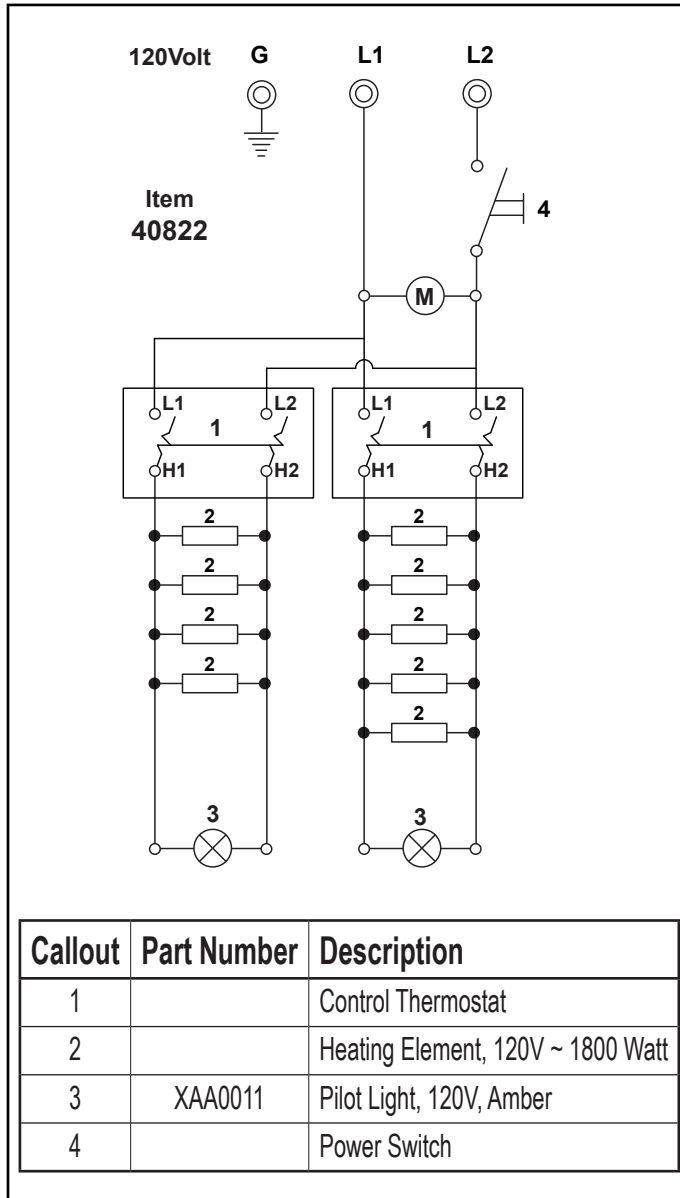

ENGLISH

WARRANTY STATEMENT FOR THE VOLLRATH Co. L.L.C.

The Vollrath Company LLC warrants the products it manufactures and distributes against defects in materials and workmanship for a period of one year, except as specifically provided below. The warranty runs 12 months from the date of original installation. (End user receipt)

1. Refrigeration compressors – The warranty period is 5 years.
2. Replacement parts – The warranty period is 90 days.
3. Fry pans and coated cookware – The warranty period is 90 days
4. EverTite™ Riveting System – The warranty covers loose rivets only, forever.
5. Cayenne® Heat Strips – The warranty period is 1 year plus an additional 1 year period on heating element parts only.
6. Ultra and Professional Induction Ranges – The warranty period is 2 years.
7. Mirage and Commercial Induction ranges - The warranty period is 1 year.
8. ServeWell® Induction Workstations – The warranty period is one year on the workstation table and 2 years on induction hobs.
9. Slicers – The warranty period is 10 years on gears and 5 years on belts.
10. Mixers – The warranty period is 2 years.
11. Extended warranties are available at the time of sale.
12. Boxer Mixers – 1 Year exchange Warranty.
13. Vollrath – Redco products – The warranty period is 2 years.
14. Optio / Arkadia product lines – The warranty period is 90 days.
15. All non-stick products (i.e. fry pans and surfaces) are 90 days for the non stick surfaces.

All products in the Jacob's Pride® collection, including the following, have a lifetime warranty:

- NSF Certified One-Piece Dishers
- NSF Certified Spoodle® Utensils
- NSF Certified Heavy-Duty Spoons with Ergonomic Handle
- NSF Certified Heavy-Duty Basting Spoons
- Heavy duty Turners with Ergonomic handle
- One-Piece Tongs*
- Heavy-Duty One-Piece Ladles*
- Nylon Handle Whips
- One-Piece Skimmers
- Tribute®, Intrigue®, and Classic Select® Cookware*

*Jacob's Pride® warranty does not cover Kool-Touch®, non stick coatings and silicone handles.

Items sold having no warranty:

- Meat Grinder Knives
- Light Bulbs in Convection Ovens and Hot Food Merchandiser
- Oven Door Seals
- Oven Door Glass
- Hot Food Merchandisers / Display Case Glass
- Calibration and set up of gas equipment
- Slicer / Dicer blades (table top food prep) – Redco and Vollrath

THIS WARRANTY IS IN LIEU OF ANY OTHER WARRANTIES, EXPRESS OR IMPLIED, INCLUDING ANY IMPLIED WARRANTY OF MERCHANTABILITY OR FITNESS FOR A PARTICULAR PURPOSE

As The Vollrath Company LLC's only responsibility and the purchaser's only remedy, for any breach of warranty, The Vollrath Company LLC will repair or, at its option, replace the defective product or part without charge, except as otherwise provided below:

- For refrigeration compressors and the second year of the warranty on Cayenne® Heat Strips and mixers, The Vollrath Company LLC will provide the repaired or replacement part only; and the buyer will be responsible for all labor charges incurred in performing the repair or replacement.
- To obtain warranty service, the buyer will be responsible to return to The Vollrath Company LLC any product (other than gas equipment that is permanently installed) weighing less than 110 lbs. or located outside of a 50-mile radius of a certified technician designated by The Vollrath Company LLC to perform warranty repairs. If a Vollrath Technician cannot be contacted check the website for service contact points. (Please refer to the Product Catalogue for weights and sizes of product)
- No remedy will be available for products that have been damaged by accident, carelessness, improper installation, lack of proper setup or supervision when required, neglect, improper use, installation or operation contrary to installation and operating instructions or other causes not arising out of defects in materials or workmanship. At the buyer's request, The Vollrath Company LLC will repair and or replace such products at a reasonable cost.
- No remedy will be available for slicers where blade has not been sharpened (Refer to owner's manual for sharpening instructions)
- No remedy will be available for mixers damaged by changing gears while unit is running or overloading, in either case as determined by a Vollrath Certified Technician
- Warranty work must be authorized in advance by The Vollrath Company LLC. See the operating and safety instructions for each product for detailed warranty claim procedures.
- No remedy will be available for product returned and found to be acceptable to the product specification.
- No remedy will be available under any warranty not registered as required below.

LIMITATION OF LIABILITY:

THE VOLLRATH COMPANY LLC SHALL HAVE NO LIABILITY FOR INCIDENTAL OR CONSEQUENTIAL DAMAGES OF ANY KIND, WHETHER BASED UPON NEGLIGENCE OR OTHER TORT, BREACH OF WARRANTY, OR ANY OTHER THEORY.



WARRANTY PROCEDURE

On all warranty calls, the following process and information is required:

- All warranty claims will start with a call to Vollrath Technical Service support line.(800-628-0832).
- A technical support professional will work to diagnose the issues, and provide the details for the service solution.
- Name and phone number of person calling
- Business name, street address, city, state and zip
- Model and serial number
- Date of purchase and proof of purchase (Receipt)
- Name of dealer where unit was purchased

NOTE: Vollrath will not accept products sent without the proper procedure being followed.

Important:

TO MAKE A CLAIM FOR ANY REMEDY UNDER THIS WARRANTY, YOU MUST REGISTER YOUR WARRANTY.

REGISTER TODAY

ONLINE: Register your warranty on-line now at www.Vollrathco.com

NO WEB ACCESS: If you do not have access to the web, kindly register by completing the warranty registration form and faxing it to The Vollrath Co. LLC office in the country of purchase.

WARRANTY REGISTRATION			
BUSINESS NAME _____			
KEY CONTACT NAME _____		EMAIL _____	
STREET ADDRESS _____			
CITY _____	STATE _____	ZIP CODE _____	
COUNTRY _____	PHONE _____	FAX _____	
MODEL _____		ITEM NUMBER _____	
SERIAL NUMBER	<input type="text"/>	-	<input type="text"/>
OPERATION TYPE			
<input type="checkbox"/> Limited Service Restaurant	<input type="checkbox"/> Full Service Restaurant	<input type="checkbox"/> Bars and Taverns	<input type="checkbox"/> Supermarket
<input type="checkbox"/> Convenience Store	<input type="checkbox"/> Recreation	<input type="checkbox"/> Hotel/Lodging	<input type="checkbox"/> Airlines
<input type="checkbox"/> Business/Industry	<input type="checkbox"/> Primary/Secondary School	<input type="checkbox"/> Colleges/University	<input type="checkbox"/> Hospitals
<input type="checkbox"/> Long-Term Care	<input type="checkbox"/> Senior Living	<input type="checkbox"/> Military	<input type="checkbox"/> Corrections
REASON FOR SELECTING OUR PRODUCT			
<input type="checkbox"/> Appearance	<input type="checkbox"/> Full Service Restaurant	<input type="checkbox"/> Availability	<input type="checkbox"/> Sellers Recommendation
<input type="checkbox"/> Ease of Operation	<input type="checkbox"/> Versatility of Use	<input type="checkbox"/> Price	<input type="checkbox"/> Brand
WOULD YOU LIKE TO RECEIVE OUR FULL-LINE CATALOG AND REMAIN ON OUR MAILING LIST?			<input type="checkbox"/> Yes <input type="checkbox"/> No

ENGLISH



www.vollrathco.com

The Vollrath Company, L.L.C.
1236 North 18th Street
Sheboygan, WI 53081-3201
U.S.A.

Main Tel: 800.628.0830
Fax: 800.752.5620

Technical Services: 800.628.0832
Service Fax: 920.459.5462

Canada Service: 800.695.8560

© 2010 The Vollrath Company, L.L.C.

