

*Turbo air Speeds Up the Pace of Innovation*

REFRIGERATOR MANUFACTURER  
***Turbo air***

**Mega Top Sandwich Salad Unit  
Sandwich Salad Unit  
Undercounter Refrigerator  
Installation and Operation Manual**

*Please read this manual completely before attempting to install or operate this equipment!*

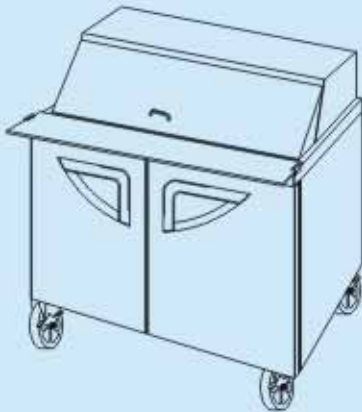

TST-28SD-12, TST-48SD-18, TST-60SD-24, TST-72SD-30



TST-28SD, TST-48SD  
TST-60SD, TST-72SD-2

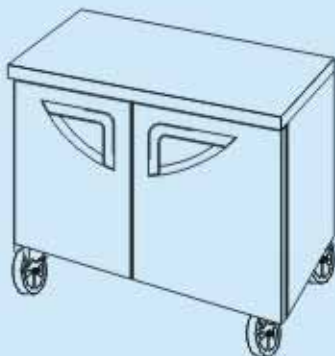

TUR-28SD, TUR-48SD, TUR-60SD, TUR-72SD

***Full Stainless Steel Visible Exterior***

# CONTENTS

|                                                       | PAGE    |
|-------------------------------------------------------|---------|
| 1. SPECIFICATION .....                                | 2       |
| 2. SERIAL NUMBER .....                                | 2       |
| 3. INSTALLATION OF CASTORS .....                      | 3       |
| 4. INSTALLATION OF DRAIN PAN .....                    | 4       |
| 5. HOW TO CLEAN THE PAN SUPPORTER .....               | 5       |
| 6. INSTALLATION .....                                 | 6       |
| 7. CLEANING & CAUTION .....                           | 7       |
| 8. BASIC OPERATION .....                              | 8       |
| 9. BEFORE REQUESTING SERVICE .....                    | 9       |
| 10. WARRANTY .....                                    | 10 ~ 11 |
| 11. STAINLESS STEEL EQUIPMENT CARE AND CLEANING ..... | 11 ~ 13 |



## SPECIFICATION

### Mega Top Sandwich Salad Unit

| MODEL       | COMP H.P | V/Hz      | REFRIGERANT | AMPS | WEIGHT |
|-------------|----------|-----------|-------------|------|--------|
| TST-28SD-12 | 1/3      | 115V/60Hz | R-134a      | 6.6A | 174lb  |
| TST-48SD-18 | 1/3      | 115V/60Hz | R-134a      | 6.5A | 247lb  |
| TST-60SD-24 | 1/3      | 115V/60Hz | R-134a      | 8.9A | 291lb  |
| TST-72SD-30 | 1/2      | 115V/60Hz | R-134a      | 9.9A | 351lb  |

### Sandwich Salad Unit

| MODEL      | COMP H.P | V/Hz      | REFRIGERANT | AMPS | WEIGHT |
|------------|----------|-----------|-------------|------|--------|
| TST-28SD   | 1/3      | 115V/60Hz | R-134a      | 6.6A | 170lb  |
| TST-48SD   | 1/3      | 115V/60Hz | R-134a      | 6.5A | 243lb  |
| TST-60SD   | 1/3      | 115V/60Hz | R-134a      | 8.9A | 284lb  |
| TST-72SD-2 | 1/2      | 115V/60Hz | R-134a      | 9.9A | 344lb  |

### Undercounter Refrigerator

| MODEL    | COMP H.P | V/Hz      | REFRIGERANT | AMPS | WEIGHT |
|----------|----------|-----------|-------------|------|--------|
| TUR-28SD | 1/3      | 115V/60Hz | R-134a      | 6.6A | 150lb  |
| TUR-48SD | 1/3      | 115V/60Hz | R-134a      | 6.5A | 221lb  |
| TUR-60SD | 1/3      | 115V/60Hz | R-134a      | 8.9A | 262lb  |
| TUR-72SD | 1/2      | 115V/60Hz | R-134a      | 9.9A | 306lb  |

## SERIAL NUMBER

The serial number is located on the rating label which is on the left interior wall. Please retain the unit's serial number for service purpose.

## INSTALLATION OF CASTORS

- 1) Screw the castor (in rear side) and the castor brakes (in front side) by using castor wrench.
- 2) Use the castor shims to level the cabinet , if necessary , by inserting them to stems of the castors.

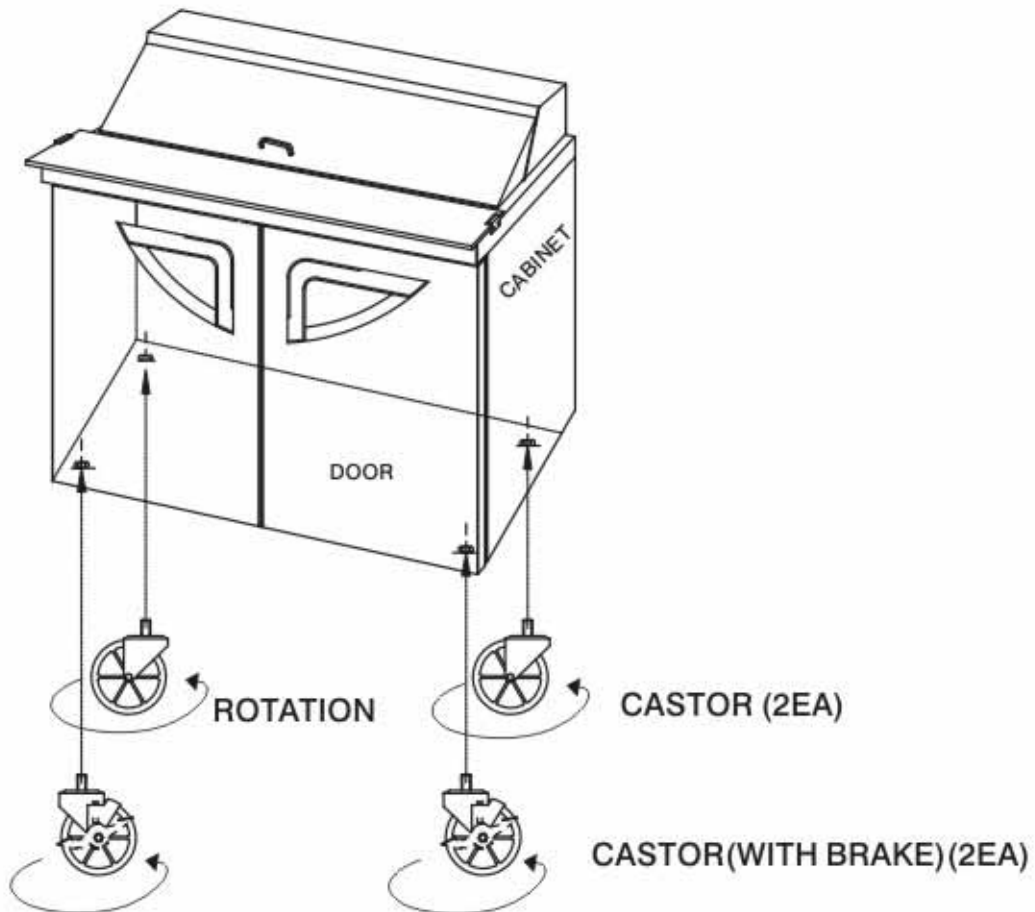

## INSTALLATION OF DRAIN PAN

1) In damp season, when the drain water overflows the drain pan, remove the drain pan and pour the water away. And then set the drain pan back up as below drawing please. (Model: TST-28SD-12, TST-28SD, TUR-28SD, )

2) When the drain pan is installed on the compressor mounted base, lift up the vaporizing pipe a bit as below drawing.

(Model: TST-48SD-18, TST-60SD-24, TST-72SD-30, TST-48SD, TST-60SD, TST-72SD-2, TUR-48SD, TUR-60SD, TUR-72SD)

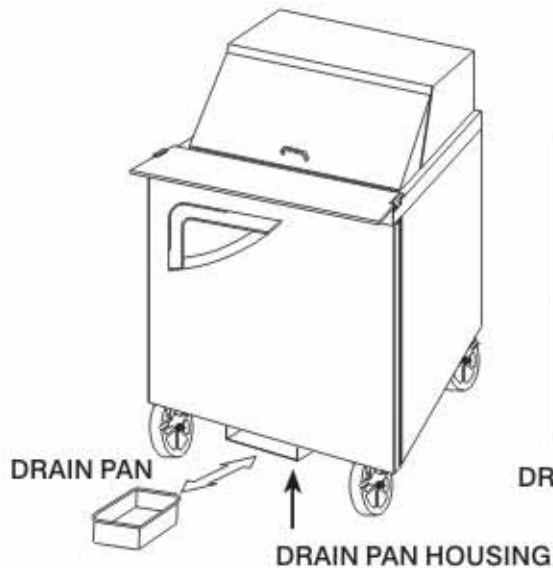

MODEL

TST-28SD-12, TST-28SD, TUR-28SD

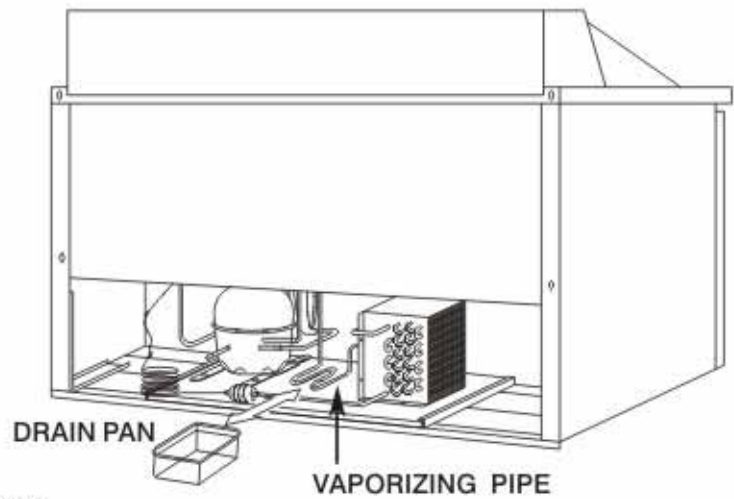

MODEL

TST-48SD-18, TST-60SD-24, TST-72SD-30

TST-48SD, TST-60SD, TST-72SD-2,

TUR-48SD, TUR-60SD, TUR-72SD

## HOW TO CLEAN THE PANSUPPORTER

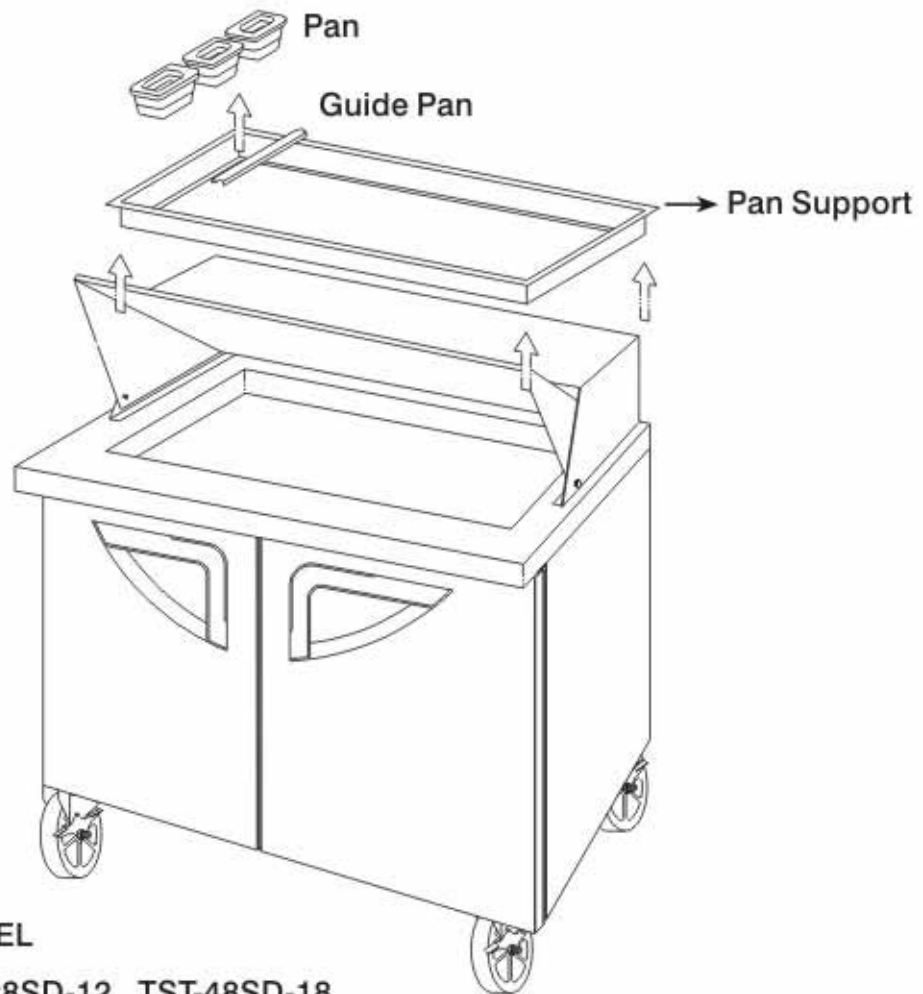

### MODEL

TST-28SD-12, TST-48SD-18

TST-60SD-24, TST-72SD-30

TST-28SD, TST-48SD

TST-60SD, TST-72SD-2

- 1) Remove the Guide Pans and Pans. Then pull out the Pan Supporter. Clean the pan supporter and reinstall in place.

## INSTALLATION

### 1. GOOD AIR CIRCULATION

- Be sure to avoid any object which may stop the air flow.
- Be sure that there is ample air space so that air can flow through the rear of the unit.
- Turbo Air recommends that the rear of the unit be no less than 5 inches from the wall.

### 2. PLACE ON STRONG GROUND

- Be sure the location chosen has a strong enough floor to support the total weight of the cabinet and any other contents.

### 3. DO NOT PLACE NEAR HEAT

- Be sure to avoid hot corners and locations near stoves.
- High ambient temperature will make much lower cooling efficiency.

### 4. INDOOR USAGE ONLY

- Be sure to install this unit indoor.
- So , it should prohibit getting wet from the rain.

### 5. STABILIZING

- Make sure the unit is installed in a stable condition with the front wheels locked while in use.

### 6. LEVELING

- Be sure that the unit is level from front to back and side to side.

### 7. UNIT SHOULD BE ON DEDICATED OUTLET.

## CLEANING

### 1. CLEANING THE INTERIOR AND EXTERIOR

- The interior and exterior of the unit can be cleaned using warm water with soap.
- Do not use an abrasive cleaner because it will scratch the surface.

### 2. COMPRESSOR AND CONDENSER

- Be sure to keep the condenser coil must be free of dust because of cooling effect higher.

### 3. CLEAN THE GASKET

- The door gasket should be cleaned frequently to maintain proper sealing.

### 4. CHECK AFTER CLEANING

- Check the unit again for safety.
- Check that the unit is operating properly.

## CAUTION

### 1. POWER CORD

- Be sure the power cord is connected to the proper voltage.
- A protected circuit of the correct voltage and amperage must be run for connection of the line cord.
- Turn 'off' the power switch before disconnecting the power cord, whenever performing maintenance functions or cleaning the refrigerated cabinet.
- Compressor warranties are void if compressor burns out due to low voltage.

### 2. RE-STARTING

- If disconnected, wait 5 minutes before re-starting.



## BASIC OPERATION

TST-28SD-12 , TST-48SD-18 , TST-60SD-24 , TST-72SD-30

TST-28SD , TST-48SD , TST-60SD , TST-72SD-2

TUR-28SD , TUR-48SD , TUR-60SD , TUR-72SD

1. The controller (thermostat) is located at the top inside of the unit.
2. The factory setting for the control is 'Normal' .
3. Setting toward "Cool" for higher temperature and "Cold" for lower temperature.

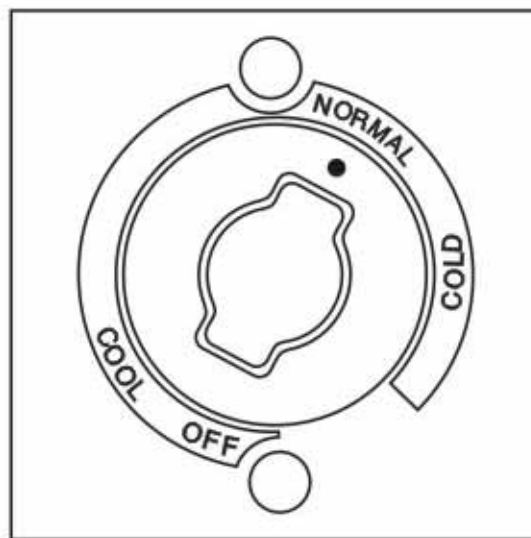

4. The thermostat controls compressor's on/off by sensing inside temperature.

## BEFORE REQUESTING SERVICE

| SYMPTOMS                                         | CAUSES                                                                                                                                                                                                                                                                                                                                | SOLUTIONS                                                                                                                                                                                            |
|--------------------------------------------------|---------------------------------------------------------------------------------------------------------------------------------------------------------------------------------------------------------------------------------------------------------------------------------------------------------------------------------------|------------------------------------------------------------------------------------------------------------------------------------------------------------------------------------------------------|
| <b>Refrigerator(Freezer) is frozen.</b>          | <ul style="list-style-type: none"> <li>• The setting temperature is too low to maintain food freshness.</li> </ul>                                                                                                                                                                                                                    | <ul style="list-style-type: none"> <li>• Turn the temperature dial to a warmer setting.</li> </ul>                                                                                                   |
| <b>The unit does not refrigerate at all.</b>     | <ul style="list-style-type: none"> <li>• There is a power connection failure problem.</li> </ul>                                                                                                                                                                                                                                      | <ul style="list-style-type: none"> <li>• Check the power cord to make sure the unit is plugged in it correctly.</li> </ul>                                                                           |
| <b>The unit does not refrigerate well.</b>       | <ul style="list-style-type: none"> <li>• The unit is in sunlight or near a heating device.</li> <li>• The unit contains hot food or too much food.</li> <li>• The unit door is opened too frequently or left open too long.</li> <li>• The temp. dial is not on the correct position.</li> <li>• The condenser is clogged.</li> </ul> | <ul style="list-style-type: none"> <li>• Move out of sunlight or away from heater.</li> <li>• Check the condition of stored food.</li> <li>• Check the position of the temp control dial.</li> </ul> |
| <b>There is a loud noise.</b>                    | <ul style="list-style-type: none"> <li>• The floor is too weak or the leveling feet are set incorrectly.</li> <li>• The backside of the unit is too close to the wall.</li> <li>• The tray is not in the correct position.</li> </ul>                                                                                                 | <ul style="list-style-type: none"> <li>• Check the installation and adjust the tray position.</li> </ul>                                                                                             |
| <b>There are dew-drops on the unit exterior.</b> | <ul style="list-style-type: none"> <li>• High-moisture air can produce dewdrops during rainy seasons.</li> </ul>                                                                                                                                                                                                                      | <ul style="list-style-type: none"> <li>• Wipe with a dry cloth.</li> </ul>                                                                                                                           |
| <b>There are dew-drops on the unit interior.</b> | <ul style="list-style-type: none"> <li>• The door is opened too frequently or left open too long.</li> <li>• Damp food is stored.</li> </ul>                                                                                                                                                                                          | <ul style="list-style-type: none"> <li>• Keep the door closed to remove dewdrops.</li> </ul>                                                                                                         |
| <b>The door does not close tightly.</b>          | <ul style="list-style-type: none"> <li>• The door is bent.</li> <li>• The unit is not level.</li> <li>• The door gasket has come out.</li> </ul>                                                                                                                                                                                      | <ul style="list-style-type: none"> <li>• Level the unit again.</li> <li>• Reposition the gasket.</li> </ul>                                                                                          |

### The following points are not malfunctions:

- A water-flowing sound can be heard when the compressor stops. This is the sound of REFRIGERANT flowing.

## Warranty

REFRIGERATOR MANUFACTURER  
**Turbo air**

### Warranty Claims

All claims for labor or parts must be made directly through Turbo Air. If unit was manufactured more than one year, proof of purchase must be faxed in or sent with claim. All claims should include: model number of the unit, the serial number of the cabinet, and all pertinent information supporting the existence of the alleged defect.

If compressor is replaced under warranty, Turbo Air will either request the compressor or compressor tag be returned. Compressor or tag must be returned with all information related to the unit. Any action or breach of these warranty provisions must be commenced within one year after said cause of action has occurred.

### One Year Parts & Labor Warranty

Turbo Air warrants to the original purchaser of every new Turbo Air refrigerated unit, the cabinet and all parts thereof, to be free from defects in material or workmanship, under normal and proper use and maintenance service as specified by Turbo Air and upon proper installation and start-up in accordance with the instruction packet supplied with each Turbo Air unit. Turbo Air's obligation under this warranty is limited to a period of one(1) year from the date of original installation or 15 months after shipment date from Turbo Air, whichever occurs first.

Any parts, covered under this warranty, that are determined by Turbo Air to have been defective within one(1) year of original installation or fifteen(15) months after shipment date from manufacturer, whichever occurs first, is limited to the repair or replacement, including labor charges, of defective parts or assemblies. The labor warranty shall include standard straight time labor charges only and reasonable travel time, as determined by Turbo Air.

### Additional Four Year Compressor Warranty

In addition to the one(1) year warranty stated above, Turbo Air warrants its hermetically sealed compressor to be free from defects in both material and workmanship under normal and proper use and maintenance service for a period of four (4) additional years from the date of original installation, but not to exceed five (5) years and three(3) months after shipment from the manufacturer.

Compressor determined by Turbo Air to have been defective within this extended period will, at Turbo Air's option, be either repaired or replaced with a compressor or compressor parts of similar design and capacity.

The four (4) year extended compressor warranty applies only to hermetically sealed parts of the compressor and does not apply to any other parts or components, including, but not limited to, cabinet, paint finish, temperature control, refrigerant, metering device, driers, motor starting equipment, fan assembly or any other electrical component, etcetera.

### 404A / 134A Compressor Warranty

The four-year compressor warranty detailed above will be voided if the following procedure is not carefully adhered to:

1. This system contains R404A or R134A refrigerant and polyolester lubricant. The polyol ester lubricant has rapid moisture absorbing qualities.
2. Drier replacement is very important and must be changed when a system is opened for servicing. A 620 copper drier or better is highly recommended.
3. Micron level vacuums must be achieved to insure low moisture levels in the system. 500 microns or lower must be obtained.
4. When compressor is grounded, suction filter drier and 620 drier or better must be replaced.
5. Compressor must be obtained through Turbo Air Inc., unless otherwise specified in writing, through Turbo Air's warranty department.

## What Is Not Covered By This Warranty

Turbo Air's sole obligation under this warranty is limited to either repair or replacement of parts, subject to the additional limitations below. This warranty neither assumes nor authorizes any person to assume obligations other than those expressly covered by this warranty.

**NO CONSEQUENTIAL DAMAGES. TURBO AIR IS NOT RESPONSIBLE FOR ECONOMIC LOSS; PROFIT LOSS; OR SPECIAL, INDIRECT, OR CONSEQUENTIAL DAMAGES, INCLUDING WITHOUT LIMITATION, LOSSES, OR DAMAGES ARISING FROM FOOD OR PRODUCT SPOILAGE CLAIMS WHETHER OR NOT BECAUSE OF REFRIGERATION FAILURE.**

**WARRANTY IS NOT TRANSFERABLE.** This warranty is not assignable and applies only in favor of the original purchaser / user to whom delivered. ANY SUCH ASSIGNMENT OR TRANSFER SHALL VOID THE WARRANTIES HEREIN MADE AND SHALL VOID ALL WARRANTIES, EXPRESS OR IMPLIED, INCLUDING ANY WARRANTY OF MERCHANTABILITY OR FITNESS FOR A PARTICULAR PURPOSE.

**IMPROPER USAGE.** TURBO AIR ASSUMES NO LIABILITY FOR PARTS OR LABOR COVERAGE FOR COMPONENT FAILURE OR OTHER DAMAGES RESULTING FROM IMPROPER USAGE OR INSTALLATION OR FAILURE TO CLEAN AND / OR MAINTAIN PRODUCT AS SET FORTH IN THE WARRANTY PACKET PROVIDED WITH THE UNIT.

**ALTERATION, NEGLIGENCE, ABUSE, MISUSE, ACCIDENT, DAMAGE DURING TRANSIT OR INSTALLATION, FIRE, FLOOD, ACTS OF GOD.** Turbo Air is not responsible for the repair or replacement of any parts that Turbo Air determines have been subjected after the date of manufacture to alteration, neglect, abuse, misuse, accident, damage during transit or installation, fire, flood, or act of God.

**IMPROPER ELECTRICAL CONNECTIONS.** TURBO AIR IS NOT RESPONSIBLE FOR THE REPAIR OR REPLACEMENT OF FAILED OR DAMAGED COMPONENTS RESULTING FROM ELECTRICAL POWER FAILURE, THE USE OF EXTENSION CORDS, LOW VOLTAGE, OR VOLTAGE DROPS TO THE UNIT.

**NO IMPLIED WARRANTY OF MERCHANTABILITY OR FITNESS FOR A PARTICULAR PURPOSE: THERE ARE NO OTHER WARRANTIES, EXPRESSED, IMPLIED OR STATUTORY, EXCEPT THE ONE (1) YEAR PARTS & LABOR WARRANTY AND THE ADDITIONAL FOUR (4) YEAR COMPRESSOR WARRANTY AS DESCRIBED ABOVE. THESE WARRANTIES ARE EXCLUSIVE AND IN LIEU OF ALL OTHER WARRANTIES, INCLUDING IMPLIED WARRANTY AND MERCHANTABILITY OR FITNESS FOR A PARTICULAR PURPOSE. THERE ARE NO WARRANTIES, WHICH EXTEND BEYOND THE DESCRIPTION ON THE FACE HEREOF.**

**OUTSIDE U.S. AND CANADA:** This warranty does not apply to, and Turbo Air is not responsible for, any warranty claims made on products sold or used outside the United State and Canada.

## Stainless Steel Equipment Care and Cleaning

**CAUTION: Do not use any steel wool, abrasive or chlorine based products to clean stainless steel surfaces.**

Stainless Steel Opponents

There are three basic things which can break down your stainless steel's passivity layer and allow corrosion to rear its ugly head.

1) Scratches from wire brushes, scrapers, and steel pads are just a few examples of items that can be abrasive to stainless steel's surface.



2) Deposits left on your stainless steel can leave spots. You may have hard or soft water depending on what part of the country you live in. Hard water can leave spots. Hard water that is heated can leave deposits if left to sit too long. These deposits can cause the passive layer to break down and rust your stainless steel. All deposits left from food prep or service should be removed as soon as possible.

3) Chlorides are present in table salt, food, and water. Household and industrial cleaners are the worst type of chlorides to use.

### **8 steps that can help prevent rust on stainless steel:**

#### **1. Using the correct cleaning tools**

Use non-abrasive tools when cleaning your stainless steel products. The stainless steel's passive layer will not be harmed by soft cloths and plastic scouring pads. Step 2 tells you how to find the polishing marks.

#### **2. Cleaning along the polish lines**

Polishing lines or "grain" are visible on some stainless steels. Always scrub parallel to visible lines on some stainless steels. Use a plastic scouring pad or soft cloth when you cannot see the grain.

#### **3. Use alkaline, alkaline chlorinated or non-chloride containing cleaners**

While many traditional cleaners are loaded with chlorides, the industry is providing an ever increasing choice of non-chloride cleaners. If you are not sure of your cleaner's chloride content contact your cleaner supplier. If they tell you that your present cleaner contains chlorides, ask if they have an alternative. Avoid cleaners containing quaternary salts as they can attack stainless steel, causing pitting and rusting.

#### **4. Water Treatment**

To reduce deposits, soften the hard water when possible. Installation of certain filters can remove corrosive and distasteful elements. Salts in a properly maintained water softener can be to your advantage. Contact a treatment specialist if you are not sure of the proper water treatment.

#### **5. Maintaining the cleanliness of your food equipment**

Use cleaners at recommended strength (alkaline, alkaline chlorinated or non-chloride). Avoid build-up of hard stains by cleaning frequently. When boiling water with your stainless steel equipment, the single most likely cause of damage is chlorides in the water. Heating any cleaners containing chlorides will have the same damaging effects.

#### **6. Rinse**

When using chlorinated cleaners you must rinse and wipe dry immediately. It is better to wipe standing cleaning agents and water as soon as possible. Allow the stainless steel equipment to air dry. Oxygen helps maintain the passivity film on stainless steel.

#### **7. Hydrochloric acid (muriatic acid) should never be used on stainless steel**

#### **8. Regularly restore/passivate stainless steel**

**Recommended cleaners for certain situations/environments of stainless steel**

A) Soap, ammonia and detergent medallion applied with a cloth or sponge can be used for routine cleaning.

B) Arcal 20, Lac-O-Nu Ecoshine applied provides barrier film for fingerprints and smears.

C) Cameo, Talc, Zud First Impression is applied by rubbing in the direction of the polished lines for stubborn stains and discoloring.

D) Easy-off and De-Grease It oven aid are excellent for removals on all finishes for grease-fatty acids, blood and burnt-on foods.

E) Any good commercial detergent can be applied with a sponge or cloth to remove grease and oil.

F) Benefit, Super Sheen, Sheila Shine are good for restoration/passivation.

CHANGES MADE TO WARRANTY COMMENCED ON 5/1/2002

✂

\_\_\_\_\_

\_\_\_\_\_

\_\_\_\_\_

Postage  
Required

✂

REFRIGERATOR MANUFACTURER  
**Turbo air**  
1250 VICTORIA ST.  
CARSON, CA 90746-1666

REFRIGERATOR MANUFACTURER  
**Turbo air**

1250 Victoria street  
Carson, CA 90746  
U.S.A. & Canada Toll Free 1-800-627-0032  
For Service 1-800-381-7770  
TEL: 310-900-1000  
FAX: 310-900-1077  
www.turboairinc.com





**NOTE:**

**PRINT CLEARLY**

**&**

**MAIL CARD IMMEDIATELY**

This card must be mailed immediately after installation date for warranty to be in effect.

**TURBO AIR** WARRANTY REGISTRATION CARD

---

(Name of your business) (Tele phone)

---

(Address) (City) (State) (Zip Code)

---

(Unit Model Number) (Unit Serial Number) (Compressor Serial Number)

This is to inform **TURBO AIR** That \_\_\_\_\_ have had the above  
(Business owner signature)

**TURBO AIR UNIT** installed in my business place. \_\_\_\_\_  
(Installation date)

The above warranties are in effect from this installation date, or 90 days after shipment from **TURBO AIR**, whichever comes first.